

AHM (RIVAROSSİ)

0-4-0 DOCKSIDE (LATE)

#34 (PILOT) AND #34 (REAR) COUPLER CONVERSION

1. Remove long front screw, located under loco at centerline of frame and cylinders, to free frame from body. Temporarily secure frame/cylinder/driver assembly with some tape wrapped around the assembly.
2. At back end of frame (by motor) cut away plastic frame spacer, approximately 1/8" behind hex head retainer screws on side of frame and 5/16" from rear end of frame. See Fig.1 for exact dimensions. Use a sharp blade and make repeated light cuts into plastic until you have cut through to metal of frame, remove and discard cut off piece. A flat horizontal strap of metal that connects both sides of the frame is exposed. This strap is 3/16" wide. Drill and tap a 2-56 coupler mounting hole exactly in the center, 3/32" from edge and on centerline of loco frame, see Fig.2.
3. Install a #34 Coupler from below using a #256 acetal plastic 2-56 screw. Cut off screw just above threaded hole. Be sure coupler is centered. Do not over tighten.
4. Before reinstalling loco superstructure, the back of the loco (below fuel bunker) will have to be trimmed at the coupler pocket to accommodate the 30-Series coupler. Remove back bottom of loco superstructure area centered between step straps and trim to clear the installed coupler. Do not cut away or damage frame retainer openings at either side of coupler pocket. Be sure opening is centered. Carefully use a trim and fit method.
5. To mount front coupler, you will need to modify loco coupler pocket opening slightly to fit the width of the 30-Series draft gear box and trim opening top flush with bottom of inside of pilot beam. Attach #34 Coupler to the front and from the bottom of the loco using an acetal plastic 2-56 screw inserted from the top and a 2-56 nut from the bottom. Tighten assembly, align with centerline of loco and cut screw off flush with bottom of nut.
6. Reassemble the loco by mounting superstructure back onto frame with the long screw.
7. Check for correct coupler height, function, and clearance and make any adjustments necessary.

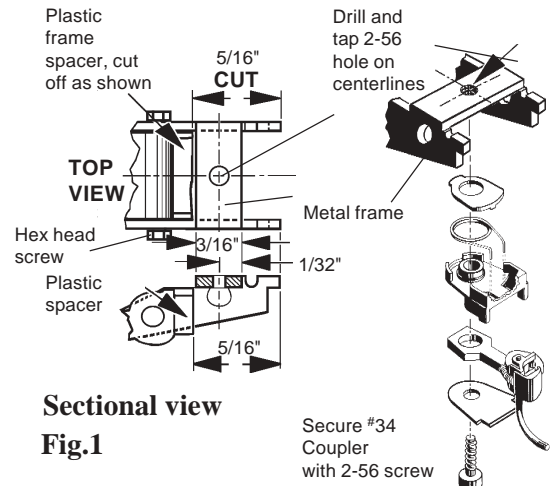

Sectional view
Fig.1

Drill and tap 2-56 hole on centerlines

Secure #34 Coupler with 2-56 screw

Fig.2

Cut to fit 30-Series Draft Gear Box. Remove back bottom of loco superstructure centered between step straps and trim to clear the installed #34 Coupler. Do not cut away or damage frame retainer openings at either side of coupler pocket.

#34 Rear Installation

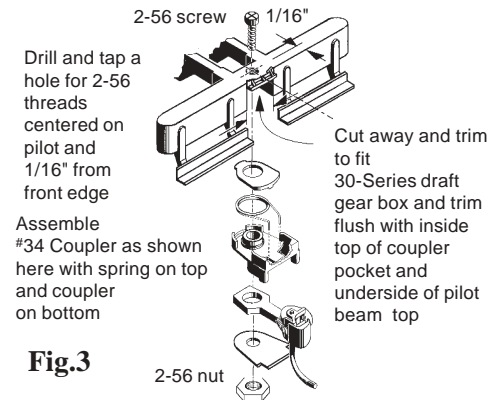

Fig.3

#34 Front Installation