

# AHM (RIVAROSSI)

# 2-8-4 BERKSHIRE

## No.5® PILOT AND TENDER COUPLER CONVERSION

1. For tender, remove rear truck and discard coupler assembly.
2. Make a shim from 1/32" thick by 5/16" wide by 13/32" long styrene. Glue in place on tender flush with inside edge of end sill and on centerline. After glue is dry, drill and tap a hole for 2-56 threads, on centerline and 1/4" from the outside edge of tender. See Fig.1.
3. Assemble No.5® Coupler and install with 2-56 x 3/16" screw. Test per Coupler Instructions.
4. For the pilot, remove dummy coupler and widen coupler pocket to 5/16" by trimming equal amounts from each side. Enlarge pocket height to 1/8" by trimming from bottom of pocket only.
5. Make a draft gear box support shim from 1/16" thick by 1/8" wide by 1/4" long styrene. Assemble No.5® Coupler, cut off side mounting lugs flush with sides and insert assembly into coupler pocket from front. Align center mounting holes, slide support shim between draft gear box and underside of pilot deck and glue in place.
6. Check for correct coupler height, function, and clearance and make any adjustments necessary.

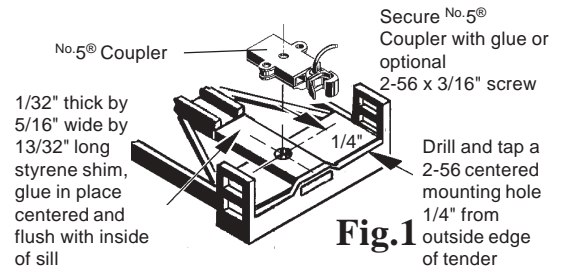

**Fig.1**

## No.5® Tender Installation

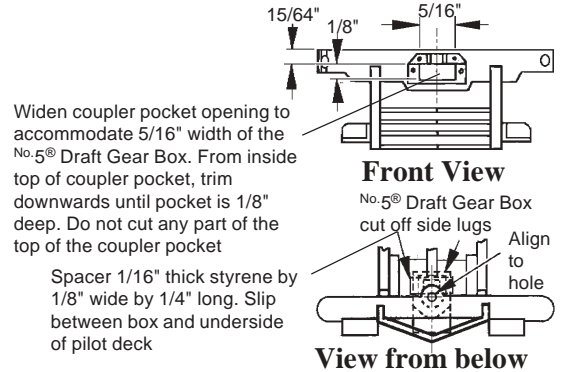

**Fig.2**

## No.5® Pilot Installation