

ATHEARN

IMPACT END CAR OR UNIT

#22 Coupler Conversion

1. Remove trucks at coupler ends and remove coupler cover/bottom strip if already assembled. Athearn Coupler pocket is just a bit too short and will need to be modified.

2. To accommodate Centering Spring, cut out a 1/32" wide notch on either side of the rear of the coupler pocket wall, see Fig.1. Place Centering Spring in Athearn coupler pocket, then insert #22 Coupler. Attach coupler cover/bottom assembly and secure. See Fig.2. Insert a thin .015" (Kadee® #208) spacer washer between trucks and bolster to raise coupler to correct height. Reattach trucks.

3. Check for correct coupler height, function, and clearance and make any adjustments necessary.

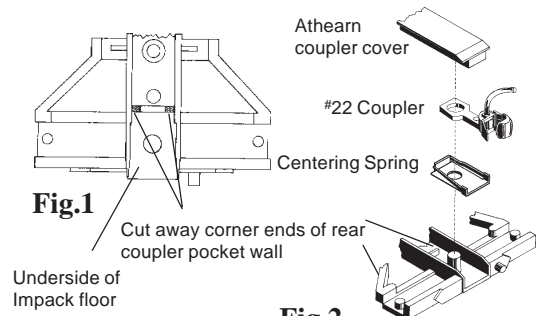

#22 Installation