

ATHEARN

EMD SW-1000 & SW-1500 (LATE)

#38 COUPLER FOR LATE MODEL CONVERSION

1. Remove the existing coupler and cover and discard both.
2. Remove paint from bottom of coupler mounting pads. Drill a 1/32" pilot hole through center of blind hole in each pad. Then drill out pilot hole with a #50 tap drill and tap for 2-56 threads.
3. Assemble the #38 Coupler with Coupler on top, Torsion Spring on bottom and lid on top of Coupler, as shown in Fig.1. Install Coupler, align and secure with a 2-56 screw.
4. You may find it necessary to file a very small amount off the top and sides of the coupler pocket opening on the loco shell to clear the 30-Series Draft Gear Box. Use the box as a guide.
5. Check for correct coupler height, function, and clearance and make any adjustments necessary.

Note: If you do not wish to tap the coupler mounting pad, drill a 2-56 clearance hole (#43) and secure the coupler with a 2-56 x 5/16" screw and a 2-56 nut.

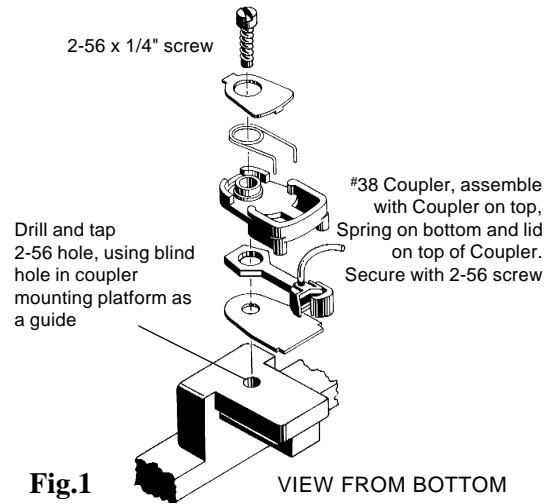

#38 Installation