

ATHEARN

EMD F-7A & B GEAR DRIVE

#37 COUPLER CONVERSION

1. Remove loco shell from chassis and remove both existing couplers.
2. Remove paint from bottom of coupler mounting pads. Drill through and tap blind hole in each pad for 2-56 threads.
3. Assemble the #37 Coupler with coupler on top and Torsion Spring on bottom as shown in Fig.1. Install coupler, align and secure with a 2-56 screw.
4. Check for correct coupler height, function, and clearance and make any adjustments necessary.

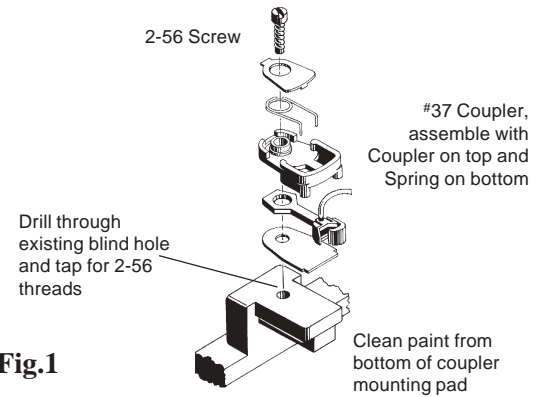

Fig.1
#37 Installation