

BACHMANN TALGO TRUCKS - ALL FREIGHT CARS

No.5® OR #37 TRUCK MOUNTED COUPLER CONVERSION

1. Remove trucks, snap on coupler pocket lids or screws and remove existing couplers. Discard couplers. For snap-on covers, add a small section of 3/32" diameter plastic tubing to enlarge the centerpost. Cut tubing the same height as the inside wall of the coupler pocket. For screw mounted couplers, inside of the sides may have to be filed back to make pocket wider to fit Centering Spring.

2. For snap-on covers, assemble the No.5® with Centering Spring on top and insert over modified centerpost. Do not use No.5® Draft Gear Box or Lid. Snap Bachmann coupler lid in place. See Fig.1. For the screw mounted coupler, use #37 Coupler with coupler on top and Torsion Spring on bottom. Modify coupler bracket by cutting off 1/2" from sides of bracket, see Fig.2. Align #37 Coupler and secure with Bachmann screw.

3. Check for correct coupler height, function, and clearance and make any adjustments necessary.

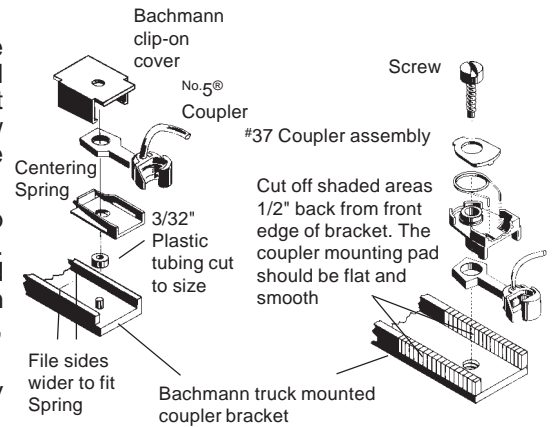

Fig.1

Fig.2

No.5® or #37 Installation