

# CON-COR

# 4-8-8-4 BIG BOY

## #33 PILOT AND #27 TENDER COUPLER CONVERSION

1. For the pilot: Remove swing-away pilot section by pushing retaining pin out of top of pilot deck, see Fig. 1. The swing-away pilot section will have to be modified by cutting away a section to provide room for a #33 Coupler assembly. Care must be exercised to assure that the 30-Series Draft Gear Box is exactly centered in the swing-away pilot section. Also when trimming this section be careful not to break off pilot bars. The top inside of the pilot opening will need to be filed smooth and flat to allow 30-Series Draft Gear Box to slide in. Fit by trial and error, be sure there is no binding.

2. Assemble the 30-Series Draft Gear Box with coupler on bottom and Torsion Spring on top, insert the assembly into the swing away pilot section and align mounting holes. Now insert the swing-away pilot coupler assembly into the matching opening in pilot and align mounting holes. Push retaining pin back in.

3. Place the loco on a test track and check for proper alignment and clearances. For permanent mounting, once you are sure everything works properly, you may wish to place a small amount of plastic compatible cement at edges of draft gear box and swing-away assembly.

4. For the tender: Disconnect loco and tender, turn tender upside down and remove coupler.

5. This is a simple conversion with two basic options. Both options use a #27 coupler. You can glue the spring into the box, if you desire. Scrape both surfaces, use a tiny spot of glue and hold it snug until set. Modify a #211 .015 Shim. Cut the side mounting lugs off and remove .035" from long end (short end goes toward the rear) see Fig. 2b.

6. Option 1: Use a #50 drill to drill a hole in the floor just in front of the bottom coupler crossbrace. Slip the drill bit between the crosspiece and the inside platform down to the floor. Hold it against the inside of the half circle of the crosspiece. Drill through the floor and the piece just under the floor. Tap the hole 2-56 through both pieces. See Fig. 2. This is the simplest and most versatile conversion. See Fig. 3.

7. Option 2: With the same coupler assembly, carefully glue the shim to the box along the edges of the two sides (a wider shim may have to be made from .015" shim stock). Scrape the surfaces of the coupler box and mounting pocket. Be sure to check coupler height before cementing. Use CA glue on the two surfaces in front of the post and the underside of the crosspiece. Use a 2-56 x 1/2" acetal screw cut in half and cement it in the hole of the coupler box. Be sure the screw head is below the edge of the crosspiece, butting against the inside of the half circle. This will add more support to the mounting.

8. Check for correct coupler height, function, and clearance and make any adjustments necessary.

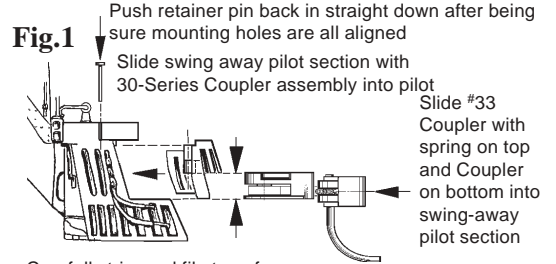

Carefully trim and file top of swing-away pilot section coupler opening to allow the 30-Series Draft Gear Box to slip fit in. Also be sure top of loco pilot opening is free of burrs and is flat.

### #33 Pilot Installation

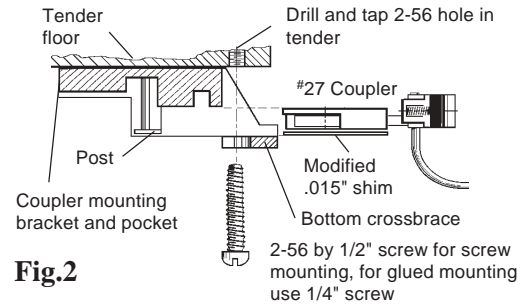

### Tender Coupler Pocket

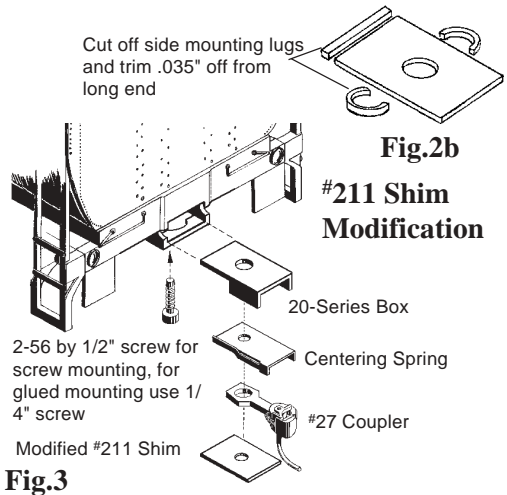

### #27 Tender Installation