

# CON-COR

# AMTRAK SUPERLINER

## #27 COUPLER CONVERSION

1. Remove existing coupler and spring.
2. Cut off coupler pocket post flush with pocket surface. File top of coupler pocket crossbar at front bottom just enough to allow the No.5® box to slip in.
3. Assemble the #27 Coupler in the No.5® Draft Gear Box (included with all 20-Series Couplers) and glue box and lid together with a small amount of plastic compatible cement placed along seams only. After glue has hardened, trim off side mounting lugs flush with box sides.
4. Slide coupler assembly in from the front between coupler pocket surface and modified crossbar. Secure coupler assembly with glue or drill and tap a 2-56 mounting hole and use a 2-56 screw.
5. Check for correct coupler height, function, and clearance and make any adjustments necessary.

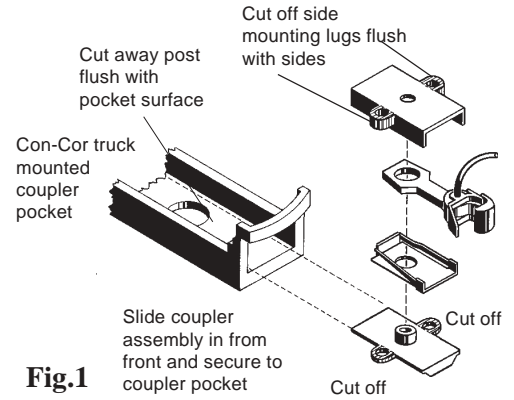

**Fig.1**  
**#27 Installation**