

has two couplers a ^{NO}5[®] and a smaller scale head #58 coupler. It would be best to use the height gauge with the ^{NO}5[®] coupler to check the height of the #118 "SF" Shelf Coupler (if desired, you can put the #118 into the height gauge). Place it and the car or locomotive on a straight and level piece of track with the couplers together. Be sure they are the same height for the best operation. With the methods of adjustment described below this can easily be achieved. Minor coupler height adjustments can be made by shimming (#211 Shims) between the car bottom and the draft gear box and / or using the #208 (.015") or #209 (.010") Shim Washers between the trucks and bolster (truck mounting position). If there is a need for an offset coupler you will have to use a standard type of coupler since there is no offset series of the "shelf" coupler. For optimum operation the trip pin should just clear the bottom plate of the height gauge and not be less than 1/64" above the Magne-Matic[®] uncoupler (between .015" and .020") and not less than 1/32" above the rail. You can use .015" and .020" thick pieces of plastic placed on the #312 and #321 Magnetic Uncouplers to check trip pin height. Use our #237 Trip Pin Pliers to carefully adjust the trip pin. Following these procedures will result in excellent delayed action uncoupling.

REPLACING KNUCKLE SPRING:

To replace a Knuckle Spring use a Kadée[®] #235 Spring Pic or the #241 "Dual Tool" and

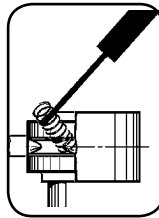
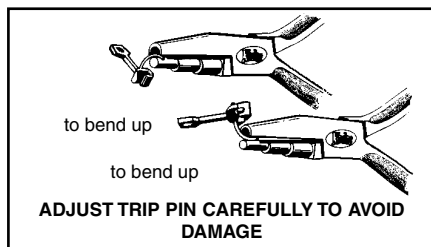

insert the tip between the last two coils of one end of the Knuckle Spring then carefully dip the last two coils of the other end into a drop of DUCO or Testors type of cement before installing on the coupler. Slip the end with the cement over the small spring post of the knuckle, compressing the spring until it can be slipped over the spring post of the shank releasing the compression until the pick can be withdrawn. Too much cement can wick into the other coils or knuckle hinge rendering the coupler inoperative. Due to the extreme wicking (capillary) action of the CA glues they are not recommended for this procedure, unless it's the thicker slow drying type.

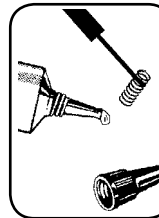

UNCOUPLERS:

For Non-Delayed Uncoupling use our #312 Between the Rails Permanent Magnet Uncoupler. For Delayed Action Uncoupling use our #321 Between the Rails Permanent Magnet Uncoupler, #308 Under the Track Permanent Magnet, or our #307 Magne-Electric (Electro-Magnet) Through the Track Uncoupler. Use our #334 Uncoupler gluing jig to aid in precision installation of the #312 & #321 uncouplers.

Kadée
Quality products co.
673 Avenue C
White City, Oregon
97503-1078 U.S.A.

© 2004 Kadée[®] Quality Products Co. 071904

Kadée[®] HO SCALE #119 "SE" SHELF COUPLER MAGNE-MATIC[®]

CONTENTS: 4 ea # 5 Draft Gear Boxes, 4 ea #118 Couplers, 4 ea Bronze Centering Springs, 2 ea Knuckle Springs

HISTORY:

(Taken from excerpts of the 1980 "The Car and Locomotive Cyclopedica" Section 9.): Recognizing the distinct safety features of the Tightlock Type "H" coupler for passenger service (adopted as alternate standard in 1937 and standardized in 1947), the Association of American Railroads (AAR) asked the Standard Coupler Manufacturers to develop a similar, but less sophisticated, design coupler for freight equipment.

This was accomplished in 1943 with the development of the Type "F" Interlocking coupler. Service trials were completed in 1947 and the Type F coupling system was made available for general freight service. It was then adopted as an alternate standard by the AAR in 1954. Due to the safety aspects of the F interlocking features in keeping cars coupled during train derailments, and preventing car overturn or telescoping, in 1970 the DOT/FRA mandated that hazardous material tank cars were to be equipped with F Interlocking couplers.

As an adjunct to the above DOT/FRA action, the coupler manufacturers, the AAR, and the tank car owners entered into a concerted cooperative effort to devise a shelf interlocking system for all AAR coupler design types that might be used on hazardous material cars. These efforts resulted in the development of top and bottom shelf retention features for the Type "E" and "E/F" couplers. Also, F couplers were provided with a top hood (shelf). These were service tested for two years. The AAR adopted the top and bottom shelf couplers as Standards for tank cars in 1975. These tank car couplers were identified by the letter "S" prefix to their catalog numbers. In 1968 the Type E couplers with a bottom retention shelf were made available and are noted as the Type "SBE" coupler. The top and bottom shelf Type "E" coupler is the "SE" coupler. The Type "F" coupler with a top hood is the Type "SF" coupler.

HISTORICALLY:

The Type "D" coupler (predecessor to the Type "E") was used from 1916, the Type "E" coupler was standard in 1932 to present, the Type "H" Tightlock passenger coupler was alternate standard in 1937 and standard in 1947, the Type "F" was an alternate standard for freight cars in 1954 and standard for hazardous material tank cars in 1970. The bottom shelf Type "SBE" was available in 1968, the top and bottom shelf Type "SE" and "SF" couplers were standard for tank cars in 1975.

#119 TYPE "SE" COUPLER:

The Kadée[®] #119 coupler represents the prototypical Type "SE" coupler which is a standard Type "E" coupler with a top and bottom shelf (also called hoods). The #119 SE coupler has the patented Kadée[®] "Whisker" centering spring intergraded into the shank and is now a once piece drop in coupler.

The top shelf can be removed and the coupler will then represent the bottom shelf Type "SBE" coupler. There would be no reason to remove the bottom shelf since our #58 and #158 already represent the standard Type "E" coupler with a medium shank and our short shank #153 and long shank #156 also are "scale head" couplers. The Type SE and SBE couplers were standardized in 1975 for tank cars and can be used prototypically on models from 1975 onwards.

The #119 is an all metal, scale head, medium length, centerset coupler with the same basic mounting dimensions as our #5, #148, #58 and #158 couplers. It has been designed and tested to function with all of Kadée's[®] HO and HO_n3 couplers, standard and scale head. Note that the top hood protrudes quite a bit and may interfere with bodywork on certain models. So there will be certain mounting limitations with the height of the top hood.

The #118 and #119 are "fully functional" shelf couplers. When two #119 couplers or a #119 and a #118 (SF) shelf couplers are coupled together the bottom shelves will keep the knuckles from sliding up or down out of each other. With these shelf couplers you can no longer simply pick up a car and expect the couplers to slip apart. You need to slightly twist the cars for the couplers to disengage or you'll end up lifting the whole string of cars. Of course you can use the operational methods of Kadée's[®] Magne-Matic[®] Delayed Action uncoupling[®] or use a manual uncoupling tool such as our #241 Dual Tool.

Please note, that because the shelves keep

the couplers from slipping apart modelers may desire to use them to keep their cars from unwanted uncoupling over rough or uneven trackage, regardless of the prototypical application of a shelf coupler. However note, there are certain limitations to shelf couplers that will cause derailments. **"Couplers are not designed to compensate for rough trackage"**. Although they may help in certain areas, do not expect them to alleviate the problems with poor modular connections, dips, bumps, gaps, sharp grade changes, or any other rough track work.

MANUAL UNCOUPLING TOOL:

There are many modelers that wish to manual uncouple with a small tool and Kadee offers the #241 "Dual Tool" manual uncoupler and spring pick combination. For manual uncoupling the #119 "SE" shelf coupler the #241 has a "pointed" end to fit around the top shelf. The other "blade" end of the #241 is for standard couplers, also, the blade end has nubs so it can double as a spring pick for inserting small coil springs.

To manual uncouple the #119 coupler with

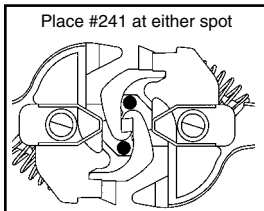
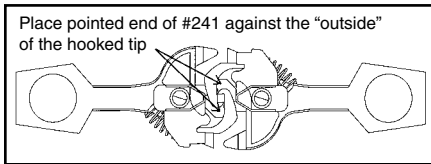

the pointed end of the #241 "Dual Tool", first push the cars together where the coupler knuckles compress against each other, insert the

pointed end against the "outside" of the hooked tip of the knuckle as illustrated (the knuckle is the moving part of the coupler head). As the point slips into the coupler it will push the knuckle past the hook of the opposing knuckle. To assist the uncoupling you can push the knuckle tip outward toward the point, when the knuckle tips are past each other you can now separate the uncoupled cars.

MODIFYING THE #119 "SE" INTO A TYPE "E" BOTTOM SHELF COUPLER OR "E" COUPLER:

The #119 is a Type "SE" shelf coupler and was used in the early 1970's (see the included historical data). If you wish to modify the #119 into a Type "E" bottom shelf coupler to be

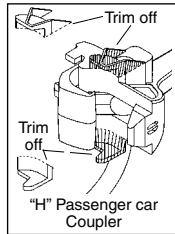
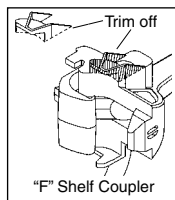

used from 1954 onward you can simply trim off the top shelf. Carefully snip off the thin top shelf area down to the level surface of the coupler head then file the area smooth and touch it up with black paint or appropriate weathering. Care should be taken not to get paint in the hinge of the coupler head. Also, by removing the bottom shelf as well as the top, the #119 can represent the Type "E" coupler.

ASSEMBLING:

Carefully study each figure and notice the relationship of one part to another.

Note: The bronze centering spring plate must "always" be installed on the top of the coupler.

Remove the draft gear box and lid from the sprue making sure the inside of the box is smooth and free of any flash. An application of Kadee® #231 Greas-em Dry Graphite Lubricant along both sides of the coupler shank will provide a polished surface that considerably reduces friction of the moving parts.

Note: the two leaves of the centering spring should be outside and resting against the end stop (the folded up piece at the end of the spring). If they are not, carefully lift them out past the edge of the end stop. Place the centering spring over the boss (centerpost) of the lid and slip the coupler onto the boss where the shank is between the two leaves (arms) of the spring.

Make sure the order of assembly matches the drawing then slide the assembly into the draft

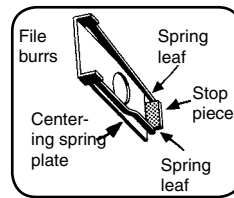
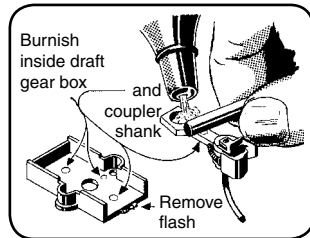

gear box carefully pressing them together. Add a "puff" of #231 Greas-em into the draft gear box opening. Move the coupler back and forth a number of times working the Greas-em around, let the coupler snap back to center position a few times checking for ease of movement. You may, when correctly assembled, cement the lid on the box using a very small amount of solvent cement carefully placed along the seams. This, however, is not necessary but only a convenience and is the modelers choice.

The draft gear box can be mounted with a screw (2-56 screw) through the center hole or with two screws through each of the two outer holes (Kadee® #401 0-48 Self Tapping Screws, use a #55 [.052"] Drill). The gear box must be mounted along the centerline of the car or locomotive.

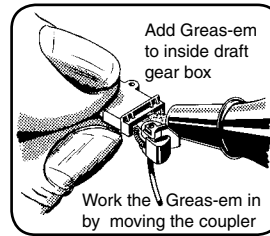

MOUNTING:

To mount on a flat surface place the coupler on centerline with the end of the gear box even with the outside edge (end) of the car. Mark the platform through the hole (about 1/4" from the end). Pre-spot the hole with a #43 (.086") Clearance Drill from our #246 Tap and Drill set. Drill (#50 Drill) and tap a hole for a machine or self-tapping screw or drill (#43 Drill) a clearance hole for a screw and nut. The side lugs can be trimmed off to fit into a tighter space or pocket. Where the use of a screw is not possible a solvent cement can be used on a styrene mount and a "CA" glue can be used for other mounts. However, you need to note that where glue or cement is used that it will be more or less a permanent mount and adjusting and servicing the coupler will be more difficult. So be sure before cementing

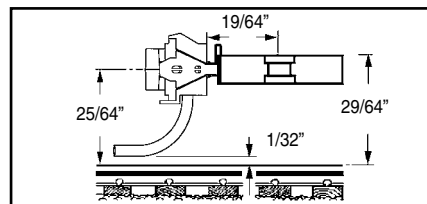

a coupler to a mount that the correct coupler height, function, and clearance is achieved beforehand.

CAST-ON DRAFT GEAR BOXES:

The coupler and centering spring will simply "drop in" many cast-on draft gear boxes (a draft gear box that is a part of molded framework or body of a car or locomotive). It will also fit into many

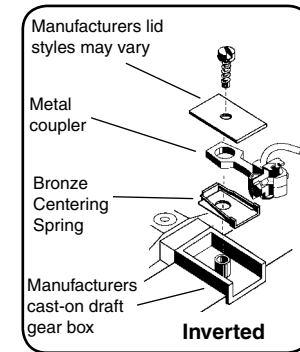

manufacturers screw on and clip on draft gear boxes. Make sure the inside of the box is free of any obstructions and flash. Test fit the spring, it must have room to flex the arms without binding.

Some manufacturer's centerpost's diameter may be too small, allowing too much coupler play and will hinder centering action. Compare the play in the #5 Draft Gear Box to the cast-on draft gear box and check if the spring functions properly. A small bushing can be made to fit over the post by filing the inside of a piece of plastic tubing (.123" outside diameter) or a bushing can be obtained from either a 20 Series coupler package or the #213 sleeve and gear box package. Another way is to use the lid from a #05 gear box, filing the inside diameter of its post hole larger before trimming the base from around the post. If the centering spring is not secure you may have to glue it into position using a very small drop of a CA type of glue.

Place the spring and coupler into the draft gear box, again making sure the spring is on top of the coupler. Place the lid on the box and secure according to the manufacturers instructions. Do not over tighten for some lids may bind the spring. On Athearn and other types of clip on lids you may need to file the edge of the tabs that the lids clip onto to relieve any binding.

CHECKING WITH HEIGHT GAUGE:

Use our #205 Height Gauge to check for the correct coupler height and trip pin clearance. The later production of the #205