



□ #786

□ #1786

COUPLER CONVERSION FOR Aristo-Craft™ RS-3 (4' radius track, 2 1/2' with some cars (coupled non-delayed)) radius is 1/2 the diameter of a circle.

Check packet, it should contain: 2ea. Couplers, 2ea. Draft Gear Boxes, 2ea. Gear Box Lids, 2ea. spring retainer caps, 3ea. Gear Box centering springs, 5ea. Coupler Centering Springs, 1ea. Knuckle Spring, 2ea. #2x3/8" screws, 2ea. #4x3/8" screws, 2ea. #4x1/2" screws, 4 ea. bushings and 2 ea. washers. Extra springs are provided should any become damaged or lost. All springs are made of stainless steel so they will not be affected by outdoor use.

Note: Not all parts will be used for this conversion. Some alterations are required of the gear box prior to assembly. Read instructions and the mounting section concerning your conversion before proceeding.

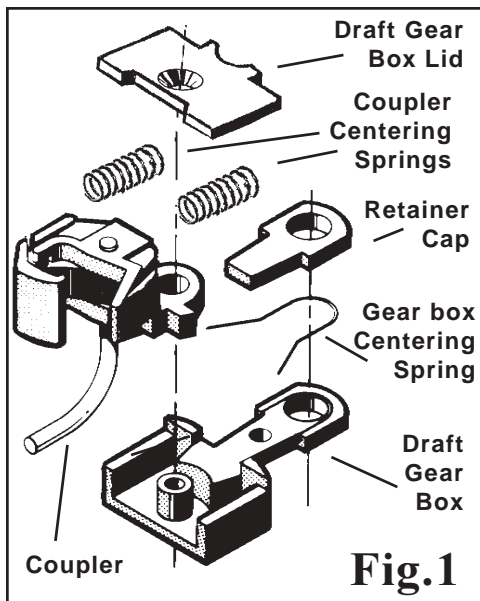

Fig.1

ASSEMBLY

1. **IMPORTANT:** Before assembling Couplers, check arrow-marked areas shown in Fig.2 for burrs and rough spots.

Remove all flash and burrs with fine file or a hobby knife to assure freedom of movement after the Coupler is assembled.

2. **Burnish** the surfaces indicated by arrows in Fig. 2 with **Kadee® #231 Greas-em**, a fine, dry lubricant specially suited for Kadee® Couplers. **DO NOT** skimp on steps 1 and 2, they are mandatory for smooth, trouble-free, Coupler performance.

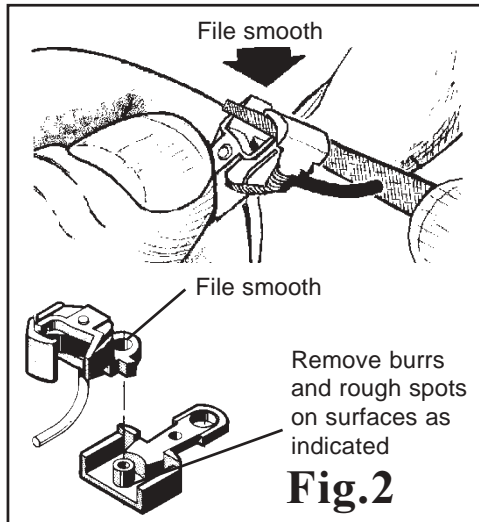

Fig.2

5. Place Coupler into Draft Gear Box as shown in Fig. 3. Add a little more **Greas-em** and work Coupler back and forth within gear box to polish.

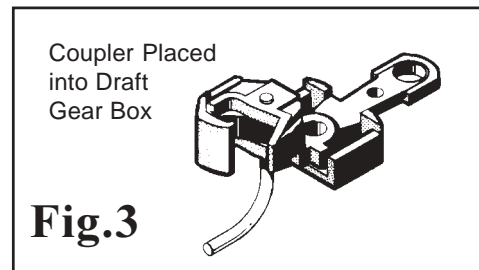

Fig.3

6. Swing Coupler to either side and install the first Centering Spring with a small screwdriver or tweezers as shown in Fig. 4. Now swing the Coupler to compress the installed spring and hold in place with your thumb. This will give you room to fit the second Centering Spring in place. After installing both springs, allow the Coupler to center itself. Then, assured the springs are properly seated, carefully place Draft Gear Box Lid on Gear box and secure with a #2 x 3/8" screw to hold in place.

5. Test Coupler centering action by working it back and forth. If it doesn't work freely and snap back to the center position, take Coupler and Draft Gear apart and start over again. It is possible that the springs aren't properly set in place or a burr is preventing proper movement.

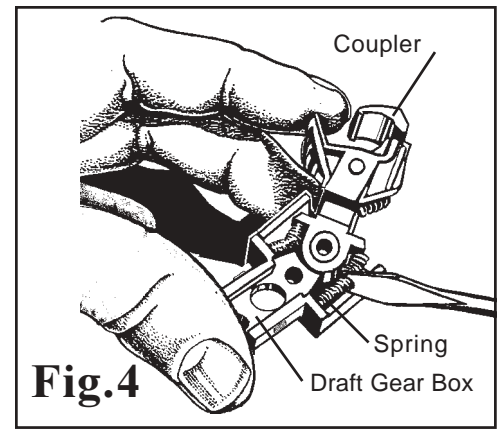

Fig.4

6. Coupler Knuckle Springs are factory installed. If one should come out during mounting, replace as follows: Insert small screwdriver blade between coils at one end of spring, then place other end of spring over either of the cone-shaped projections in the knuckle spring slot. Compress spring until the end can be slipped over opposite cone, see Fig. 5. Use only #860 Kadee® G Scale Knuckle Springs or #1875 Kadee® #1 Scale Knuckle Springs designed for this purpose. Any substitutions will not allow the coupler to work properly.

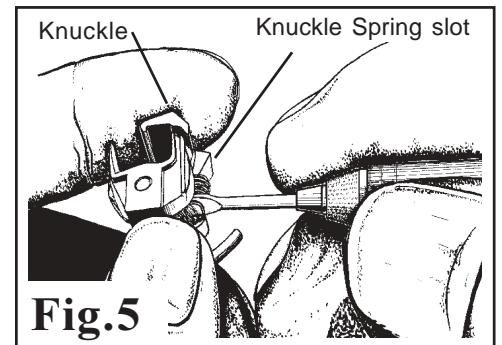

Fig.5

7. Coupler Assembly is now ready for mounting. **NOTE:** If after extended use, the Coupler does not snap back to center as when new, it is because the uncoupling action tends to collapse one centering spring more than the other and it takes a slightly shorter set. To correct this, simply remove and switch springs from one side to the other.

MOUNTING

ARISTO-CRAFT™ RS-3 4' RADIUSTRACK

NOTE: Before drilling any holes mark the hole with a sharp pointed center punch. This will act as a guide for the drill bit.

Very carefully drill a 1/16" hole in the back of the draft gear box as straight and level as possible .055" (just under 1/16") from

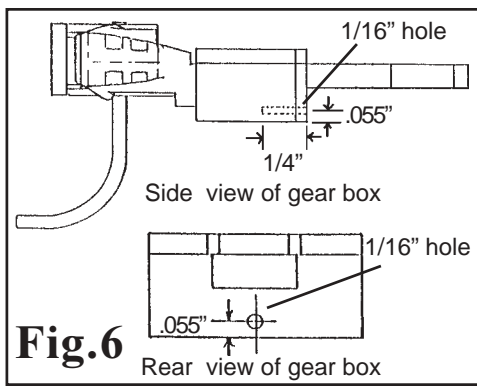

the bottom and on the centerline 1/4" deep, just short of the boss (center pivot post) **Fig. 6.** Drill the hole (for the retainer cap post) the rest of the way through the gear box shank, using a 3/32" drill. The retainer cap will be placed on the opposite side of the shank, **Fig. 7.** Assemble the coupler according to its instructions, omitting the wire gear box centering spring. Remove any burrs from drilling. Place the assembled coupler onto the coupler mounting post followed by the retainer cap and secure with the original screw and washer. **NOTE: Make sure there are no burrs on mounting post that will interfere with the couplers operation.** Reinstall the straight centering spring and slip into the 1/16" hole in the back of the draft gear box. Secure with it's original screw (tweezers and grippers will assist here). Note: If the 1/16" hole broke though the floor of the draft gear box, be sure to clean any burrs and check if the end of the straight spring

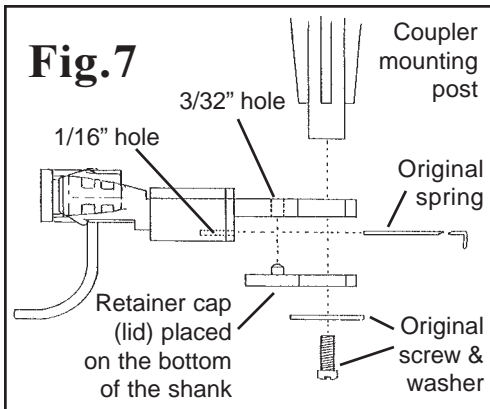

interferes with the coupler. If so, trim off the appropriate amount from the spring, only enough to eliminate the interference. Check for correct coupler height, function and clearance. If the centering action doesn't bring it back to center, remove the straight spring and adjust (carefully bend) as needed. Be sure the spring clears the screw head on the top of the mounting post.

OPERATION

One of the many desirable features of Kadee® Magne-Matic® Couplers is their ability to perform "delayed uncoupling". **TO COUPLE:** Simply push cars together. Upon touching, the operating knuckles move to opposite sides then couple in a closed position. Only a "feather touch" is required to couple. **TO UNCOUPLE:** Stop over a Magnetic Uncoupler so your Kadee® Magne-Matic® Couplers are approximately half way over the Uncoupler. You must create slack between the Couplers which will allow them to be drawn open by the

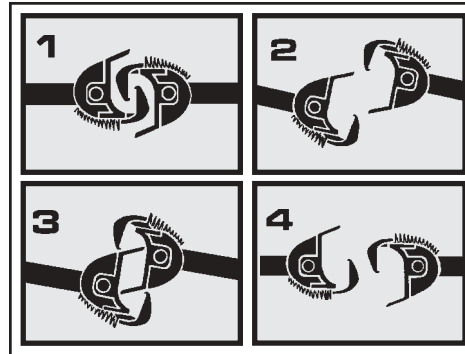

magnetic force acting on the two Trip Pins. Each Coupler has a wire or "Trip Pin" extending down from its knuckle, towards the track, that looks like an unhooked air hose. **See #1. Note:** You may find it best to pull the train past the magnet, then back the cars over it. Now, when you pull forward, the Couplers disengage. At this point, magnetic force will draw the Couplers off-center, **see #2.** Couplers will hold this position as long as they remain over the magnet. When you back up, bringing Couplers together again over the magnet, they will not recouple, but will mismatch in the "delayed" position, **see #3.** With a single Kadee® Uncoupling Ramp, you can set the Couplers on one car, or a string of cars, in the "delayed" position for spotting cars at several points beyond the Uncoupler. Just push the car or cars to the desired location and drop off. As you pull forward again, the two Couplers in the "delayed" position separate and snap back to their normal centered position, ready for recoupling, **see #4.** Kadee® Magne-Matic® "delayed action" uncoupling has unlimited possibilities for realistic operation of your railroad. Kadee® Couplers work even better than the prototype because they work automatically, with nothing touching them.

Use Kadee® #231 Greas-em, the dry lubricant recommended for use with all Kadee® Magne-Matic® Couplers. Greas-em will not attract the dirt and dust that

gums up the inside of couplers like oil, grease or other lubricants will.

Use Kadee® #840, #841, #842, and #844 **Magnetic Uncouplers** with our G and #1 scale Couplers. **The #840 and #841 Uncouplers** are mounted in the track section of your choice, either LGB™ #840, or Kalamazoo #841. **#842 Uncouplers** come without track and are for mounting in LGB™ or other similar tracks. It will be necessary to cut the track, complete instructions are included. **#844 Uncouplers** also come without track and are for use with LGB™ or other similar types of track. No cutting of the track is necessary. We cannot guarantee the satisfactory operation of our Couplers if other kinds of magnets are substituted for the Kadee® Magnetic Uncouplers.

NOTE: To prevent damage to couplers: If you plan to store your equipment in the original box, the gear box may need to be modified to properly allow clearance for your new Kadee® Couplers. Simply cut openings in the gear box ends to give extra clearance for Kadee® Couplers.

MAGNE-MATIC®

Kadee Quality products co.
673 Avenue C
White City, OR 97503

Made in the U.S.A.