



#828

ASSEMBLY:

1. Remove any flash and rough spots & burnish the "arrow" marked surfaces shown in Fig. 2 with Kadee® #231 Greas-em to ensure trouble-free coupler performance.
2. Place coupler into Draft Gear Box, as shown in Fig. 3. Add a little more #231 Greas-em and "toggle" coupler back and forth in box to burnish further.
3. Place coupler and Draft Gear Box together. While holding (optional Kadee® #1020 Tweezers), install Centering Spring into spring slot (behind post except the #806 Coupler the Centering Spring is placed in front of post) using a Kadee® #241 Spring Pic or small screwdriver wedged between the last two coils of the spring, see Fig. 4.
4. Place Draft Gear Box Lid on box, being careful not to dislodge Centering Spring, then slip tweezers out. While holding lid in place, test coupler centering action by toggling it back and forth. Coupler should move freely and automatically snap back into center position. If it does not, disassemble coupler, check for proper spring seating, then reassemble.
5. Coupler Knuckle Springs are pre-installed. If one should come out during mounting - replace as follows: Insert Kadee® #241 Spring Pic (or small screwdriver) between end coils of spring, see Fig. 5. Place opposite spring end over cone shaped

projection in Knuckle Spring slot, then compress spring until opposite end can be slipped over other cone. Remove Spring Pic, do not substitute any other spring for Knuckle Spring. To assure proper coupler operation, use only Kadee® appropriate Knuckle Springs.

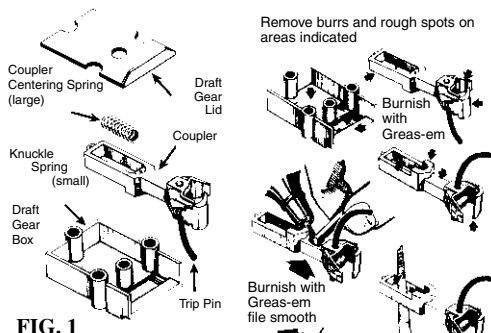

FIG. 1

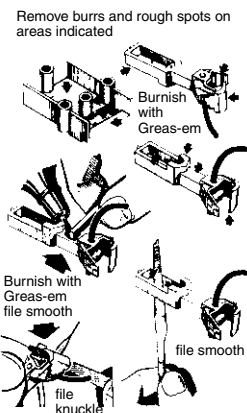

FIG. 2

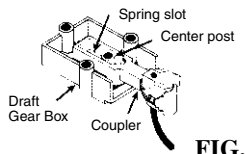

FIG. 3

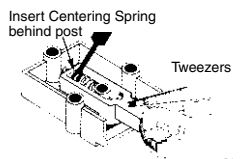

FIG. 4

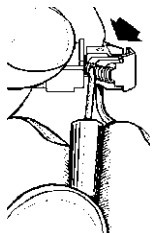

FIG. 5

When properly mounted on cars the flex bracket included in this packet will allow operation on shorter radius track. The flex bracket must be mounted on the car centerline.

The flex bracket is secured to the gear box using one of the 4-40 screws (Fig. 6)

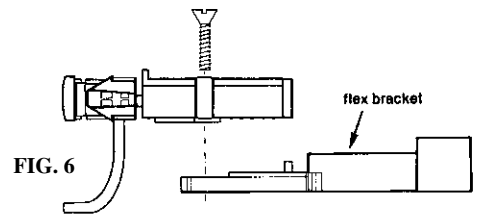

FIG. 6

MOUNTING:

Place the flex bracket in the proper location shim if necessary and mark through the screw holes. Remove the flex bracket and drill clearance holes (3/32") through the underbody. The flex bracket is now secured using the 2-56 screws and nuts supplied. (Fig. 7 & 8)

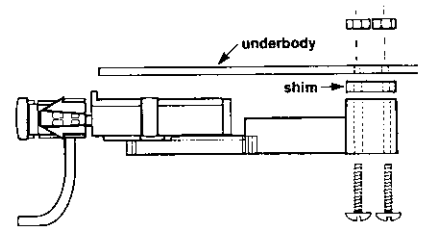

FIG. 7

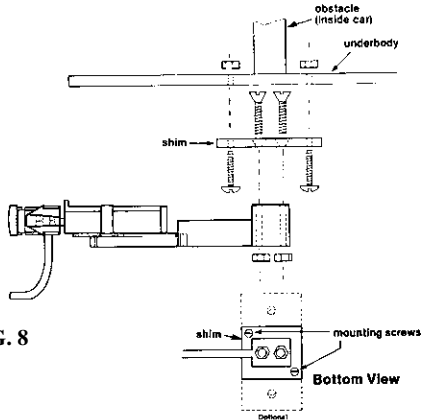

FIG. 8

Note: Kadee's® #1020 tweezers are very helpful for holding the 2-56 nuts in position inside the car.

For some unusual mountings or if there is a clearance problem in the mounting screw area (perhaps with the axle) the flex bracket can be installed upside down. In this case the supplied shim is used. The mounting area can be cut out for clearance (Fig.9). This method of mounting will lower the coupler.

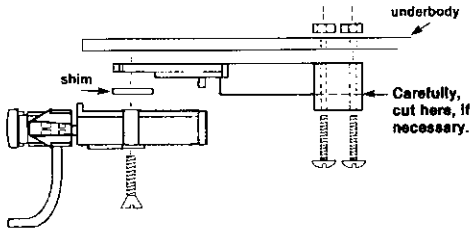

FIG. 9

COUPLER OPERATION

TO COUPLE -

Simply push cars together until knuckles bypass each other and lock into position.

FOR DELAYED UNCOUPLING -

1) Stop with the couplers over an uncoupler and back up slightly with the couplers still over the uncoupler, allowing slack to occur between couplers. 2) Pull forward slightly. Couplers are now in the delayed position. 3) Back up, pushing the car(s) to the desired location. Do not permit slack to develop between couplers. 4) Pull forward, leaving the car(s) where desired. Couplers automatically return to normal coupling position.

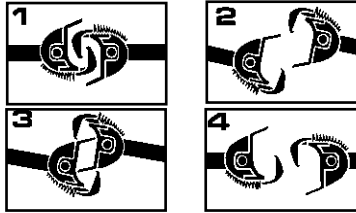

NOTE: If couplers swing open too far when uncoupling, lower magnet slightly to correct.

Use Kadee® Greas-em, the dry lubricant recommended for use with all Kadee® Magne-Matic® couplers. Greas-em will not attract the dirt and dust that gums up the inside of couplers like oil, grease or other lubricants will. Use our #829 #1-Scale or #880 G-Scale Height Gauge to check for the correct coupler height and trip pin clearance. The N.M.R.A. standard for coupler height is the centerline of coupler is 1 1/16" (1.0625") for #1-Scale & 1 1/8" (1.125") G-Scale.

Note: We include extra knuckle springs. The Replacement Knuckle Spring used on Kadee® #1-Scale couplers are sold as the #875 (#819-828 couplers) or #1875 (1700 & 1800 series couplers) Knuckle Spring. The Knuckle Spring used on Kadee® G-Scale couplers are sold as the #860 Knuckle Spring.

For Delayed Action Uncoupling use our #842 Uncoupler, #844 Portable Uncoupler, or our #840 Uncoupler mounted in LGB track.

Kadee® coupler conversion list & coupler conversions are on the Kadee® web site for your convenience.

www.kadee.com/conv/convpl.htm

MAGNE-MATIC®

WARNING:
CHOKING HAZARD - Small Parts
Not for children under 14 years.



Made & Assembled Entirely
in the U.S.A.

Kadee®

Quality Products Co.

673 Avenue C,
White City, OR 97503-1078
022309

©2009, Kadee® Quality Products Co.