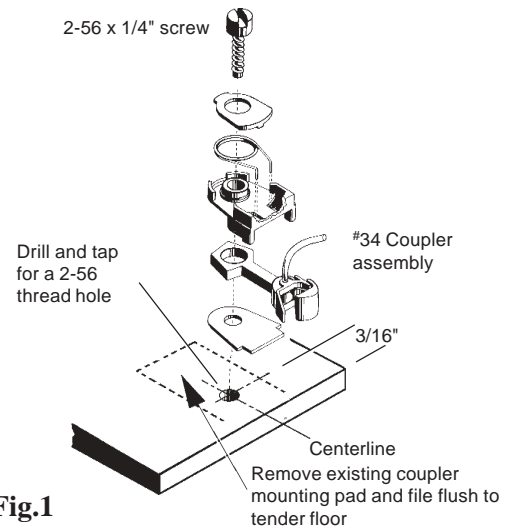

**#34 TENDER ONLY (REAR) COUPLER CONVERSION**

1. Turn loco over and detach tender from engine. Be careful not to lose the flexible coupling shaft between loco and tender.
2. Remove existing coupler and trim coupler mounting pad flush to tender floor. Remove plastic with light, repeated cuts and file flat and smooth.
3. Drill and tap a 2-56 threaded coupler mounting hole located 3/16" from back end of tender and exactly on centerline.
4. Secure assembled #34 Coupler to tender floor. Be sure coupler is aligned with centerline of tender. Do not over tighten.
5. Check for correct coupler height, function, and clearance and make any adjustments necessary.

**Fig.1****#34 Tender Installation**