

**ATLAS KATO - JAPAN****EMD SD-9****#38 COUPLER CONVERSION**

1. Remove Atlas retainer pin and existing couplers.
2. Modify both pilot and rear coupler openings to make them wide enough to accept 30-Series Draft Gear Box width of 5/16". File a small amount of plastic from the right hand side wall of the coupler opening, looking from the front end of the locomotive to align the coupler on center and, if necessary, a small amount from bottom of opening. Do not file top of opening.
3. Assemble #38 Coupler with Coupler on top and Spring on bottom. Do not use the coupler lid.
4. Insert coupler assembly into coupler opening and secure with Atlas retainer pin.
5. Check for correct coupler height, function, and clearance and make any adjustments necessary.

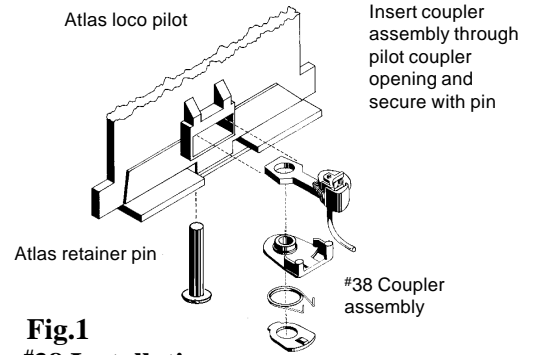

**Fig.1**  
**#38 Installation**