

ATLAS KATO - JAPAN

ALCO C 424 PHASE I & II AND C 425

No.5® COUPLER CONVERSION

1. Remove Atlas retainer pin and existing couplers.
2. Modify pilot coupler opening to make it wide enough to accept No.5® Draft Gear Box width of 5/16". File equal amounts from each side, do not file top of opening.
3. Assemble No.5® Coupler per instructions, modify Draft Gear Box by cutting side mounting lugs off flush with sides of Draft Gear Box. Glue lid to box with plastic compatible cement applied sparingly at joints only.
4. Insert coupler assembly into coupler opening and secure with Atlas retainer pin.
5. Check for correct coupler height, function, and clearance and make any adjustments necessary.

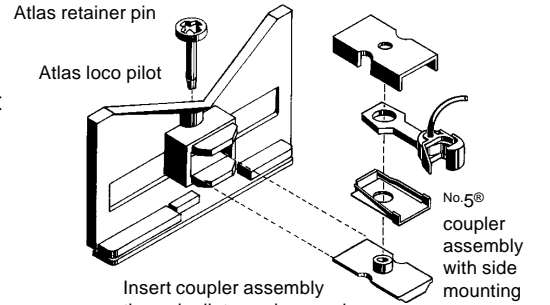

Fig.1

Insert coupler assembly through pilot coupler opening and secure with pin

No.5® coupler assembly with side mounting lugs cut off

No.5® Installation

VIEW FROM BOTTOM