

# BACHMANN SPECTRUM

# EMC GAS ELECTRIC

## "DOODLEBUG"

### No.5® OR #31 REAR COUPLER CONVERSION

1. Pilot: It is not recommended to convert the pilot, there's just too little to work with.
2. Rear: It is not recommended to convert the Bachmann swing coupler box, as even with a #27 offset coupler the coupler will be too low. See "Special Note" below.
3. For larger radii track: Use a No.5® Coupler and box in place of Bachmann swing box. Remove body, small screw connecting end of articulating arm and drop the box out. Assemble No.5® Coupler and carefully glue lid to box. Trim lip off the lid. Secure through pivot hole with 2-56 screw and nut trimmed to appropriate length.
4. For smaller radii track use a #454 Swing Bracket with a #31 Coupler. See "Special Note" and #454 Swing Bracket below. Instructions are similar for gas electric and passenger car, see Fig's 4 & 5, but use a #31 Coupler.
5. Check for correct coupler height, function, and clearance and make any adjustments necessary.

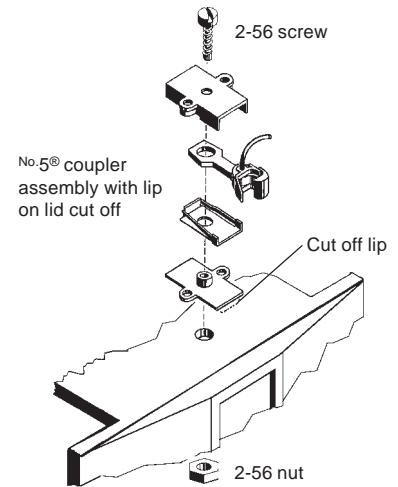

**Fig.1**

**No.5® Installation**