

# LIFE-LIKE PROTO 2000

**Note:** We recommend using the #32 Coupler and drilling and tapping a mounting hole to secure the coupler with a screw. If you do not wish to drill and tap the locomotive frame, then we recommend the #22 Coupler be held by the modified coupler retaining clip.

## #32 COUPLER CONVERSION

1. After removing the chassis from the shell, spread the side wall of the plastic coupler clip and remove it and the coupler from the chassis.
2. Drill and tap a 2-56 hole all the way through the existing hole in the coupler mounting platform. File off the burrs smooth and flat.
3. Assemble the #32 Coupler per instructions with the Torsion Spring on top Lid on bottom and secure to mounting pad with a 2-56 screw of appropriate length. See Fig.1.
4. Check for correct coupler height, function, and clearance and make any adjustments necessary.

## #22 COUPLER CONVERSION

1. Remove the chassis from the shell. Remove the clip by spreading the side walls.
2. It will be necessary to modify the coupler retaining clip by filing the clips engaging latch projection on the inside edge just enough to allow clearance for the #22 Coupler to swing freely as shown in Fig. 2.
3. With the plastic clip held upside down, place the Centering Spring over the clip centerpost. Next place the #22 Coupler over the centering post on top of the spring with the shank end of the Coupler between the spring legs.
4. Place clip over mounting platform aligning centerpost with hole and snap clip into place. Check for freedom of movement.
5. Check for correct coupler height, function, and clearance and make any adjustments necessary.

# BL-2 DIESEL

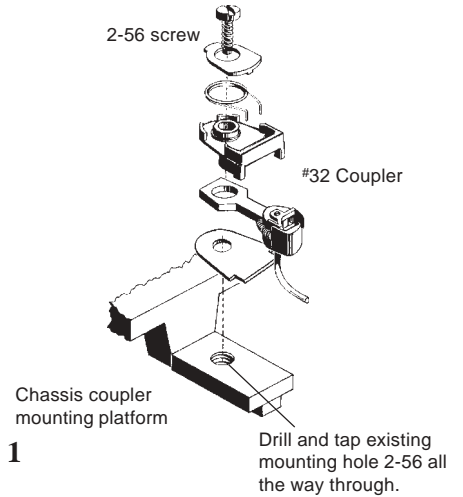

**Fig. 1**  
**#32**

## Installation

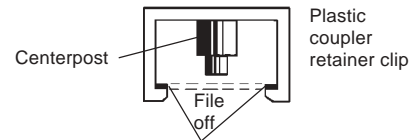

**Fig. 2**  
**#22 Installation**

Modify by filing away top inside of clip engaging latch