

LIFE-LIKE PROTO 2000

AUTO BOX CAR 50'

#33 COUPLER CONVERSION

1. Remove and discard existing draft gear box and coupler.
2. There are two small holes on the coupler mounting pad. Use a #50 drill to drill out the rear hole and then tap it with a 2-56 tap.
3. Assemble the #33 Coupler according to the instructions with the spring on top of the coupler and the lid on the bottom.
4. Secure the coupler to the mounting pad with a plastic 2-56 screw and trim off excess
5. Check for correct coupler height, function, and clearance and make any adjustments necessary.

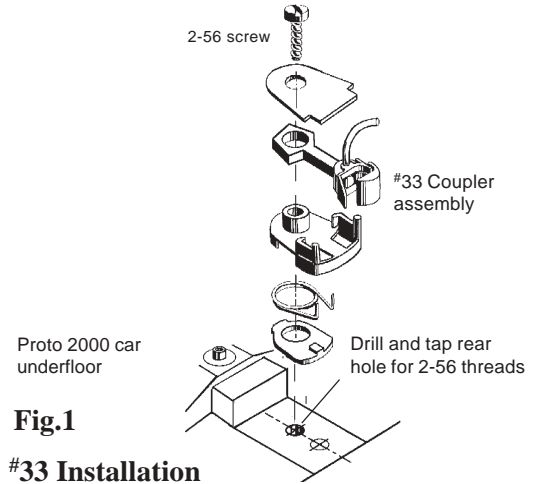

Fig.1

#33 Installation

NO.5® OR #58 COUPLER CONVERSION

1. Remove the screw and existing coupler. Save screw.
2. Assemble the No.5® or #58 Coupler with Centering Spring on top. Place Lid on Draft Gear Box and secure with screw.
3. Check for correct coupler height, function, and clearance and make any adjustments necessary.

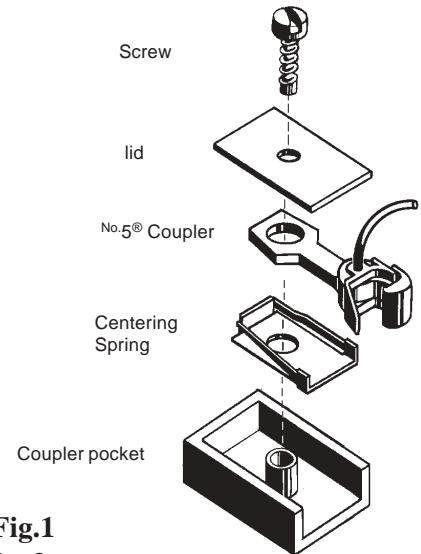

Fig.1

No.5® or #58 Installation