

TYCO

2-6-2 PRAIRIE

#37 COUPLER CONVERSION

1. Remove existing couplers, save screws.
2. Check both coupler openings with 30-Series Draft Gear Box. If not wide enough, remove material equally from both sides until opening is 5/16" wide.
3. For pilot: Assemble #37 Coupler with Torsion Spring on bottom, Coupler on top with lid. Use a .015" thick Shim (Kadee® #211) between top of coupler and bottom of pilot deck. Modify #211 Shim by cutting off side mounting lugs flush with sides. Install shim and #37 Coupler in pilot from below and secure with Tyco screw.
4. For tender: Assemble #37 Coupler with Torsion Spring on bottom, Coupler on top with Lid. Install 30-Series Coupler from below and secure with Tyco screw.
5. Check for correct coupler height, function, and clearance and make any adjustments necessary.

For pilot only: Use a .015" shim between top of coupler and bottom of pilot deck. Modify #211 Shim by cutting off side mounting lugs flush with sides

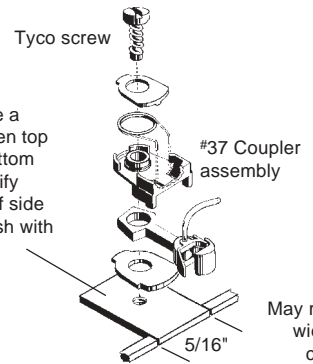

May require widening coupler opening to fit 30-Series Draft Gear Box

Fig.1
#37 Installation