

VARNEY

No.5® COUPLER CONVERSION

4-6-0 TEN WHEELER (CASEY JONES)

1. Remove trucks, coupler pocket lid and couplers. Discard couplers.
2. For tender: Widen coupler pocket to 5/16". Drill and tap a 2-56 coupler mounting hole, 1/4" from pocket end on tender centerline. See Fig.1.
3. Make shims 5/16" wide by 3/8" long with a 2-56 clearance hole in center or use Kadee® #211 shims with side mounting lugs cut off to lower No.5® Coupler to correct mounting height. See Fig.1.
4. For pilot: Cut coupler pocket off at bottom of pilot beam. Repeat step 2. See Fig.2.
5. Assemble No.5® Coupler and install with shims using 2-56 screw.
6. Check for correct coupler height, function, and clearance and make any adjustments necessary.

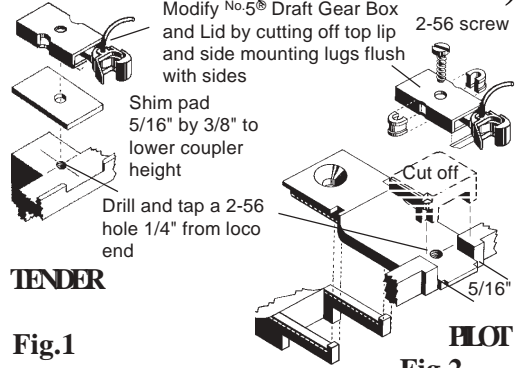

Fig.1
No.5® Installation

PILOT
Fig.2