

BACHMANN CHINA

#37 COUPLER CONVERSION

1. Remove locomotive shell and the coupler mounting bracket from the chassis. (Some newer chassis do not have a removable bracket).
2. Modify coupler mounting bracket by cutting off the shaded portion of the side walls and centerpost flush. Center punch and drill a 1/32" pilot hole in center of previous centerpost location. Drill through pilot hole with a #50 tap drill and tap for 2-56 threads. If you do not wish to drill and tap a hole, enlarge pilot hole to 1/16" and use a 0-48 x 1/4" self-tapping screw.
3. Assemble the #37 Coupler with coupler on top and Torsion Spring on the bottom. Do not use the coupler lid. Install coupler assembly from below onto the coupler mounting bracket. Align and secure with 2-56 screw.
4. Check for correct coupler height, function, and clearance and make any adjustments necessary.

EMD F-9

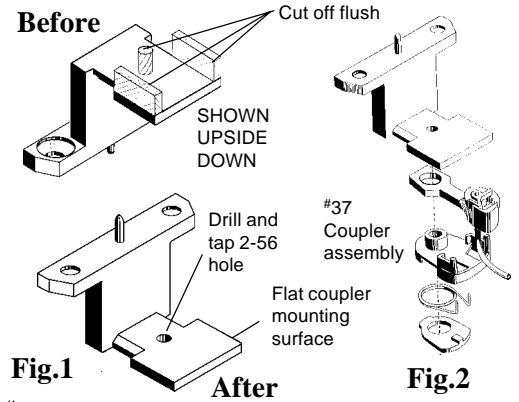

#37 Installation