

# CON-COR

# EMD MP-15

## #22 COUPLER CONVERSION

1. Remove the chassis from the body shell. Remove and discard existing screws and couplers. Modify Con-Cor coupler pockets by cutting off centerpost flush. File coupler mounting surface smooth and flat.
2. Assemble the #22 Coupler per instructions into the No.5® box (included in #22 package). Glue box and lid together with a small amount of plastic compatible cement placed along seams only. After glue has dried, cut off flange lip on top of box lid flush with box surface.
3. Mount #22 Coupler assembly centered on coupler pocket mounting pad flush with front of pocket. Glue in place with small amount of plastic compatible cement.
4. File bottom of truck gear box covers until they clear uncoupler ramp.
5. Check for correct coupler height, function, and clearance and make any adjustments necessary.

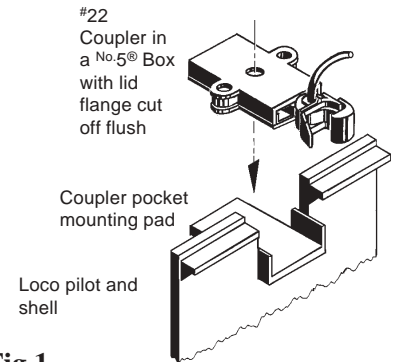

**Fig.1**  
**#22 Installation**