

# CON-COR

# EMD SD-40

## #38 coupler Conversion

1. Remove the chassis from the body shell.
2. File the coupler pilot opening down to .150" and widen equally to .300" to allow the 30-Series coupler assembly to enter.
3. Drill and tap the coupler mounting hole in the shell for 2-56 threads.
4. Assemble the #38 Coupler with the coupler on top and the Torsion Spring on the bottom, without the lid. Use a 2-56 screw to secure coupler to shell.
5. Check for correct coupler height, function, and clearance and make any adjustments necessary.

**Note:** If truck underframe does not clear an uncoupling magnet, we suggest filing the gear housing projections down until the truck clears the magnet.

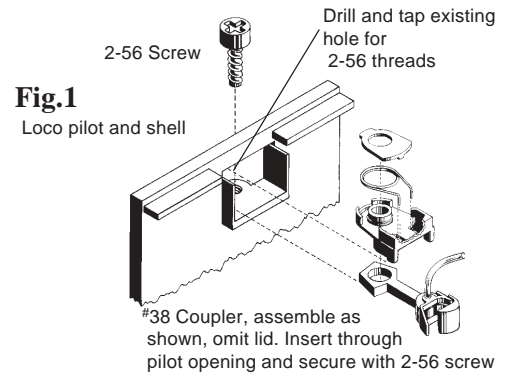

## #38 Installation