

# IHC MEHANO-SLOVENIA

# 2-6-0 MOGUL

## #38 PILOT AND #28 OR #38 TENDER COUPLER CONVERSION

1. For pilot: Remove original coupler, pilot wheels and spring. Cut the two sides and lower portion completely off the pilot coupler opening, leaving the upper lip as is. File the sides smooth and straight to the left and right vertical bracing. File the bottom even with the bottom of the upper lip. File tip of pilot back and round to clear Trip Pin.
2. Cut a piece of 1/16" thick shim stock 3/16" x 3/8" to fit between the chassis rails under the pilot platform. Glue shim to platform. Make sure it fits flush against the edges.
3. Assemble the #38 Coupler with the spring on the top and lid on bottom. Slip the coupler into the pocket. Hold the coupler firmly and mark the position of the hole and coupler. You can either drill and tap a hole or cement the coupler in place. Be sure, before cementing, that the coupler is at the correct height. For a more secure mount fill gap on the bottom with a small shim cut to size and glue in place. See Fig.1.
4. For tender: Remove existing couplers. For truck (Talگو) mount, use a #28 Coupler. Install coupler with snap lock Talگو Truck Adaptor per coupler instructions. To body mount, remove the tender body from the chassis and remove rear truck from tender floor and cut off Talگو coupler box from truck, see Fig.2. Do not lose screw and nut.
5. Fabricate a coupler mounting pad from 1/16" thick styrene shim stock 3/8" by 1/2". Place one end flush against the back inside end of tender shell. It may be necessary to file or cut a notch on the top edge of shim to clear the stanchion protrusion. Make sure pad is level, glue in place with a plastic compatible cement. See Fig.3.
6. Glue the coupler assembly in place on centerline, with the gear box just past the edge of the pad where the coupler clears the end of the tender. Check for correct height before you glue pad in place. To mount the coupler using a screw, place it as mentioned above and mark the hole. Drill and tap a 2-56 hole through the platform. Secure coupler assembly with a 2-56 screw. Reinstall trucks and reassemble the tender.
7. Check for correct coupler height, function, and clearance and make any adjustments necessary.

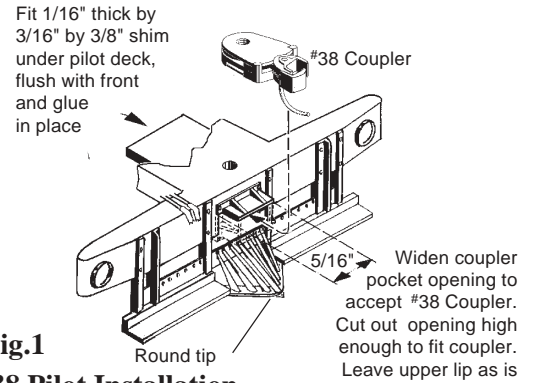

**Fig.1**  
**#38 Pilot Installation**

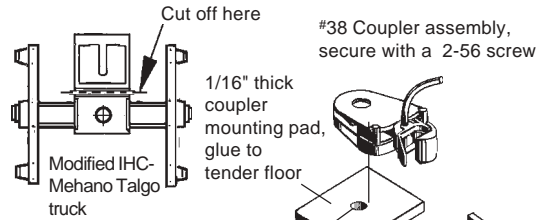

**Fig.2**  
Drill and tap 2-56 hole on centerline and 1/4" from edge through coupler mounting pad and tender floor

**Fig.3**  
**#38 Tender Installation**