

KATO JAPAN

No.5® COUPLER CONVERSION

1. Remove Kato retainer pin and existing couplers.
2. Modify both pilot and rear coupler openings to make them wide enough to accept No.5® Draft Gear Box width of 5/16". File a small amount of plastic from the side walls of the coupler opening to align the coupler on center and, if necessary, a small amount from bottom of opening. Do not file top of opening.
3. Modify the No.5® Draft Gear Box and Lid by cutting off side mounting lugs flush with sides. Assemble No.5® Coupler. Insert coupler assembly into coupler opening from the front and secure with Kato pin. See Fig.1.
4. Check for correct coupler height, function, and clearance and make any adjustments necessary.

EMD GP-35

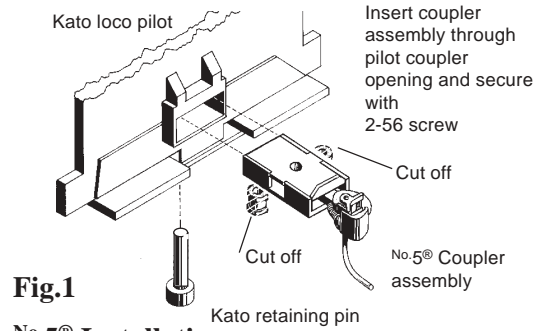

Fig.1

No.5® Installation