

KATO JAPAN**GEC 44-9CW DASH 9****#38 COUPLER CONVERSION**

1. Remove Kato retainer pin and existing couplers. Discard couplers.
2. Assemble the #38 Coupler according to 30-series instructions, without lid and with the spring on the bottom of coupler.
3. Slide assembly into the coupler pocket opening, it will be a snug fit. Line up the holes of the draft gear box and coupler platform and secure with Kato coupler pin.
4. Check for correct coupler height, function, and clearance and make any adjustments necessary.

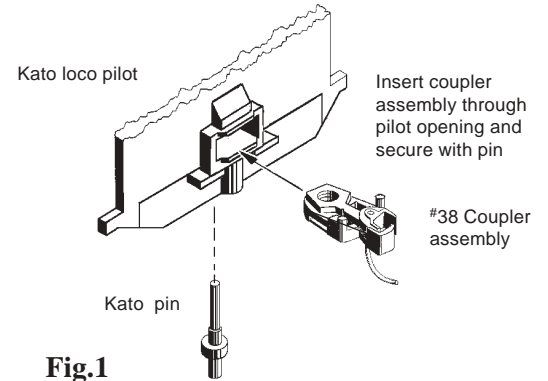

Fig.1
#38 Installation