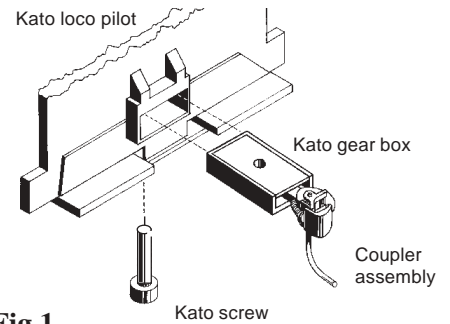

**KATO JAPAN****EMD SD-40-2****#28 W/PLOW, #23 REAR COUPLER CONVERSION**

1. Remove the screw and remove coupler pocket from mounting platform. Save screw.
2. Remove the existing coupler.
3. Pilot: assemble the #28 Coupler with Centering Spring on top. Place Lid on Draft Gear Box. place coupler pocket back in mounting platform and secure with screw.
4. Rear: assemble the #23 Coupler with Centering Spring on top. Place Lid on Draft Gear Box. place coupler pocket back in mounting platform and secure with screw.
5. Check for correct coupler height, function, and clearance and make any adjustments necessary.

**Fig.1****#28 W/Plow, #23 Rear Coupler Conversion**