

MDC - ROUNDHOUSE**HARRIMAN PASSENGER CAR****NO.5® OR #58 TRUCK MOUNT COUPLER CONVERSION**

1. Remove existing screw, lid and coupler on both ends. Save screws and lids.
2. Assemble the No.5® Coupler with Centering Spring on top and place in coupler pocket over centerpost.
3. Place lid over coupler assembly and the cast-on coupler pocket and secure with the original screw.
4. Check for correct coupler height, function, and clearance and make any adjustments necessary.

NO.5® OR #58 BODY MOUNT COUPLER CONVERSION

1. See manufactures instructions. Follow the instructions included with the couplers for assembly and adjustment.
2. Remove existing coupler and draft gear box if already assembled.
3. Assemble the No.5® or #58 Coupler with Centering Spring on top. Place Lid on Draft Gear Box.
4. Align coupler assembly on car centerline and secure to coupler mounting platform with a screw.
5. Check for correct coupler height, function, and clearance and make any adjustments necessary.

Note: Some minor variations occur depending on type of car or production run. This may require the addition of one or more shim washers between truck and bolster for correct coupler height. Metal frames and/or metal coupler pockets should have plastic couplers. See individual cars listed below for additional specific instructions.

042104

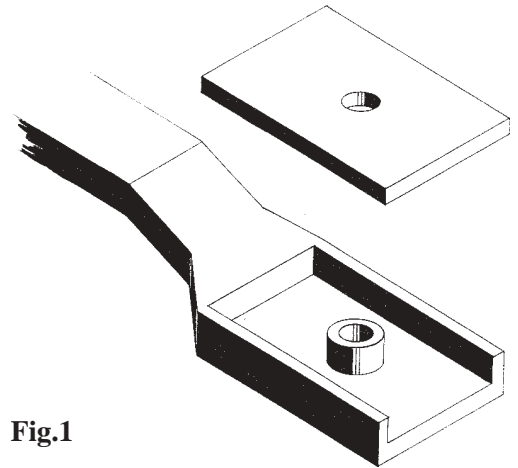
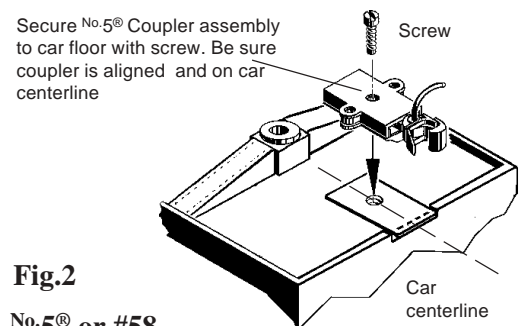
**Fig.1****No.5® or #58****Truck mount Installation****Fig.2****No.5® or #58****Body mount Installation**