

the better. Be careful removing the wheels because the metal can break. Set the truck on the car and line the holes up, lay the bolster on the coupler pocket and move it forward or back to the correct coupler position as above. Mark the bolster where the centerpost touches it and where the edge of the top plate is. Note in the

illustration how to file the bolster to fit into the pocket and onto the post. The shank of the bolster will hook over the post and be pulled forward, so adjust the hole to retain the correct coupler location. File the slot into a keyhole shape, as shown, with the large end big enough to fit over the post. Slip the bolster into the pocket and note where the front cross bar hits and where the ends of the sidewalls touch the shank. This is where you need to file the shank narrower as shown in the illustration. File very small amounts at a time and check the fit often until the bolster fits snugly and sets flat against the top plate without binding against the front cross bar. Place the bolster into the truck and pull it forward hooking under the "T" of the post. Place the wheels back in the truck and temporarily secure the bolster with a rubber band or a piece of tape. Set it on the track and check the coupler height. These usually come out to the correct coupler height and if they do not you are limited to minor shimming or using an offset coupler as mentioned previously. When you achieve the correct coupler height and length use a small drop of CA glue on the back area of the bolster to secure in place.



To replace the knuckle spring, use our #241 Dual Tool (Manual Uncoupling Tool & Spring Pic) and insert it between the last two coils on either end of the spring. Then slip the end of the spring onto one of the retaining cones and compress the spring until you can slip the other end onto the opposing cone then withdraw the pick.

NOTE: To secure the knuckle spring more durably carefully dip the last two coils in DUCO® (or similar type of glue) or a thick slow drying CA glue ("do not" use the thin CA glue because it can easily "wick" into the knuckle and ruin the coupler). Then slip the end of the spring onto one of the retaining cones and compress the spring until you can slip the other end onto the opposing cone then withdraw the pick.

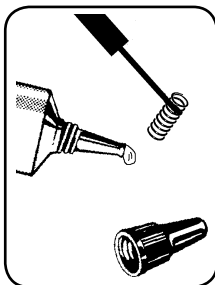

WARNING:
CHOKING HAZARD - Small Parts
Not for children under 14 years.

DELAYED
MAGNETIC
UNCOUPLING

Kadee
Quality Products Co.
062118



Made in the U.S.A.
673 Avenue C,
White City, OR 97503-1078

©2018, Kadee® Quality Products Co.



505 & 508 Conversion Bolster Instructions

Check the package for the following contents: 2ea. #505 or #508 Bolsters, 2ea. #5 Couplers, 2ea. Centering Springs, 2ea. 0-48 x 1/8" Self-tapping Screws, 2ea. 0-48 x 3/16" Self-tapping Screws.

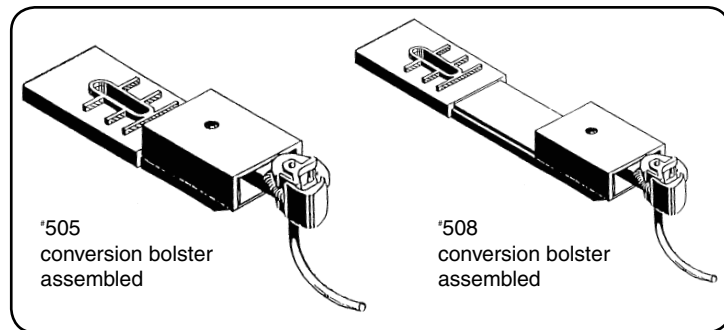

The #505 and #508 conversion bolsters (brackets) are for the truck mounted coupler pockets on AHM, IHC, Rivarossi, and most Con-Cor passenger cars. Also the IHC after market plastic and metal passenger car trucks will use these. The metal trucks require a different procedure and are handled in a separate section of these instructions.

The shorter #505 is for 6 wheel trucks and the longer #508 is for 4 wheel trucks. Of course, there are exceptions like the 72 foot Con-Cor passenger cars that have their 4 wheel trucks mounted closer to the end of the car than usual and therefore uses the #505 instead of the normally used #508. Also, there have been some 6 wheel trucks being used as 4 wheel trucks simply by removing the middle set of wheels.

These bolsters, when mounted correctly, provide a very stable and secure coupler platform that does not "float" or "wobble" in the pocket as some of the "snap in" couplers.

Both bolsters come complete with metal #5 couplers with an insulated draft gear box specially made to fit the bolster. The centering spring of the #5, and 20 series couplers is always assembled on top of the coupler.

Read the instructions carefully and completely before you begin.

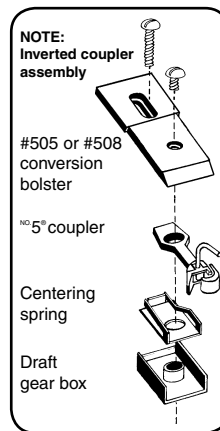

NOTE: Inverted coupler assembly

It is recommended to assemble the couplers to the bolsters before installing them on the trucks. Study the assembly illustrations to see how the parts fit together. Begin by removing the parts from the small sprue and trim or file any flash and gate marks (the point where the part connects to the sprue). Hold the draft gear box with the open side up and place the bronze centering spring plate over the post, making sure it sets flat and even in the box. Burnish (polish) the top and bottom of the coupler shank with the smooth end of a twist drill, or similar tool, along with some of our #231 "Greas-em" dry graphite lubricant. This reduces friction and improves coupler performance. Place the coupler over the post and into the spring making sure that the arms of the spring are correctly along the angled end of

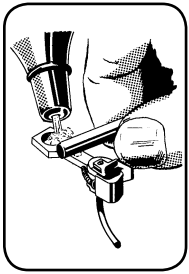

the coupler shank. Now place the bolster onto the box, lining up the small holes, making sure that the edges of the box are on the stepped down sides of the bolster and the ends are flush with each other. Turn the assembly over and flip the coupler back and forth to check the centering action. Place a small 1/8" 0-48 self tapping screw through the countersunk hole in the bolster and into the box then tighten just snug but not too tight. Add a puff of graphite lubricant into the draft gear box and move the coupler back and forth to spread the graphite and polish the inside.

With the bolster right side up (trip pin pointing down) note the raised bosses (spacers) around the slot and the end. These spacers are designed to make allowances for the early production AHM cars that have undersized wheels. If the wheels are replaced with the correct size 36 inch wheels the coupler pocket will be too high and the spacers compensate for this and lowers the coupler to the correct NMRA Standard coupler height. NMRA coupler centerline height is 25/64" (.390") above the rails. If you retain the original wheels then you would remove the bosses. The later production AHM and the IHC, Rivarossi, and Con-Cor passenger have the correct 36 inch wheels installed, so for these cars the bosses will need to be removed. Also, to fit some of the coupler pockets you need to remove the bosses. Trim the bosses down to the surface of the bolster shank and file smooth.

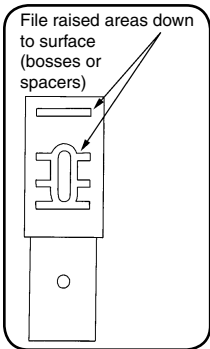
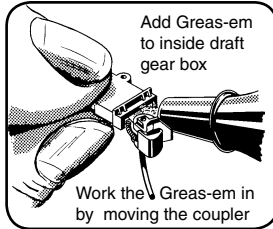

To install, remove the trucks from the car, they usually are attached to a plastic or metal press fitted pin. On the 6 wheel trucks remove the middle wheelset to expose the pin. Put your finger on the pin, to keep it from popping out, and carefully pull up on the truck. Be careful, if the pin is too tight the plastic ones could break easily. Use a thin blade screwdriver to pry the pin up a little then use a pair of pliers to finish removing the pin. Remove the front wheelset over the coupler pocket. Turn the truck right side up (wheels down). At the front of the pocket there is a bar across the bottom, some will have an arc on the inside edge and some will be straight. On top of the bar there are two sidewalls and at the end of each there will be a turned in lip or an "L" shaped turn in of the sidewalls, this makes the opening too narrow for the bolster to slide into the pocket. Trim these off even with the inside of the sidewalls and file smooth. The centerpost that attaches to the top plate needs to be trimmed out level with the plate surface. Slip the bolster into the pocket and slide it back to the end. Most of the front cross bars are too thick and will not allow the bolster to set flat against the plate. Remove the bolster and file the top of the front bar as level as possible until the bolster will set flat against the plate. If you have the earlier AHM model and need to leave the spacers on the bolsters you will need to remove the front cross bar. This, however, does take away the added strength of the bar and eliminates an extra place to secure the bolster if necessary. So be sure it is really necessary to remove the bar.

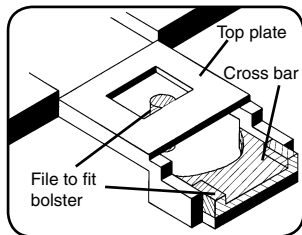

The plate may have a round or square hole and the thickness of the plate may vary, even from one truck to another on the same car.

Use a #56 drill (found in the "1059 package) and drill a hole along the centerline half way between the front of the plate and the forward edge of the hole. However, with the various differences in the trucks it may be better to slip the bolster into the pocket and use it to help locate the best place for the hole. Slide the bolster back into the pocket as far as possible. Invert the car and set the truck in place and align the holes. Now check the location of the coupler head (knuckle) with the end of the car. It should be where the

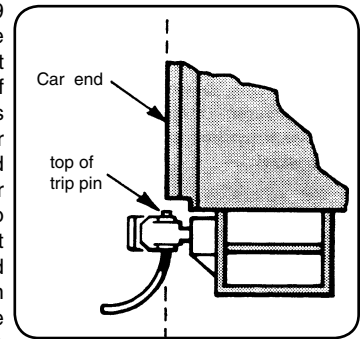

top of the trip pin is lined up with the outermost edge of the car, this includes the door sill. Through the screw slot check to see how much of the plate is showing and mark the platform as close to the center as possible, try to leave some room for adjustment of the bolster. You can leave the bolster in the pocket to drill the hole if you wish. Use the #56 drill and carefully drill a hole through the plate. Put the 0-48 x 3/16" self-tapping screw through the slot and into the hole then tighten to just snug. If the screw protrudes too far and hangs up or catches on the underframe you will have to trim it off for the needed clearance. Do not over tighten, it is easy to strip the hole especially if the plate is thinner than normal. If you do strip the hole simply use an 0-80 screw in the slot and a hex nut on top of the plate. Use the shortest screw

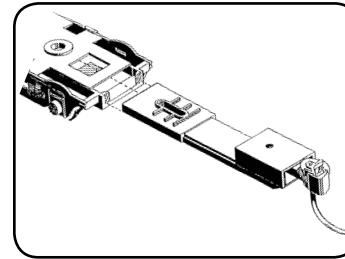

possible so it does not drag or catch on the underframe. If the plate is too thin to hold a screw securely you can use a #56 drill and drill a hole through the front cross bar and into the shank of the bolster and use a slightly longer 0-48 screw. Having a screw through the front bar takes away the coupler length adjustment so check to be sure of the coupler location beforehand.

Put the wheels back into the truck and set it on the track and check the coupler height and trip pin clearance (use our #205 or #206 Coupler Height Gauge). Most of these conversions do not need any coupler height adjustments but if needed you can add shims between the bolster and top plate if the coupler is too high. Also you can use any of our offset couplers (from the Kadee® plastic 20 or metal 140 series whisker® couplers) in the bolsters draft gear box to raise or lower the coupler height. The #27 or #147 coupler would raise the knuckle and the #22 or #142 coupler would lower the knuckle.

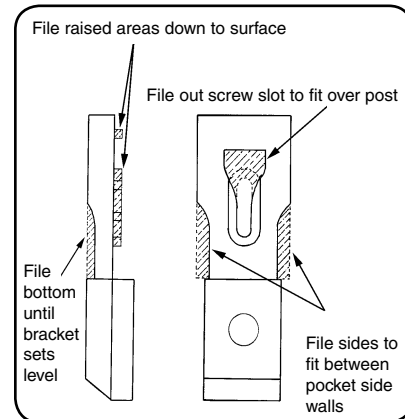

Reinstall the trucks to the car, and the middle wheels on the 6 wheel trucks, check the clearance under the car and make any necessary adjustments.

For the IHC metal after market trucks, assemble the coupler and trim the bosses on the bolster as above. Since the trucks are die cast metal it is easier to modify the bolster rather than the truck. Study the illustration for this conversion and use a slow trim and fit method, the tighter the fit