

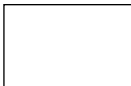

#702



1 KIT

COUPLER ASSEMBLY FIXTURE

FOR USE WITH
KADEE®
#711, #712,
#713, & #714
COUPLERS



ASSEMBLY:

Trim flash from parting lines & assemble as shown in Fig 1. Attach to a work surface with base screws.

INSTRUCTIONS:

1. Place draft gear box over fixture nest pin. (see illustration).
2. Put trip pin in coupler shank.
3. Place coupler shanks over draft gear center post with trip pin through nest. Carefully and slowly release coupler clamp so it clamps coupler knuckle. **Caution: Do not allow fixture clamp to snap forward.** Assemble centering spring into coupler shank and lid onto draft gear box according to coupler instructions.
4. Very carefully, use CA glue along edges of gear box and lid to secure. Your couplers are now ready to install.

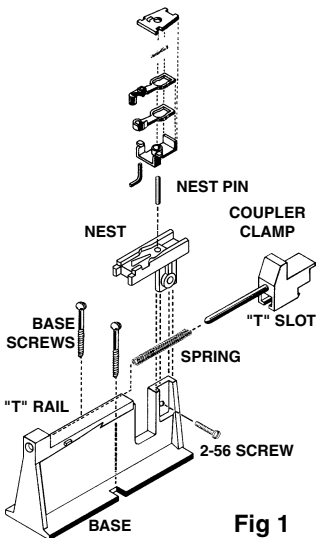

Fig 1

Kadee®

Made Entirely in the U.S.A.

Quality Products Co.

673 Avenue C, White City, OR
97503-1078

©2009, Kadee® Quality Products Co.
012609

All Kadee® products are Guaranteed*

WARNING:
CHOKING HAZARD - Small Parts
Not for children under 14 years.

