

NEM 360

NEM 360

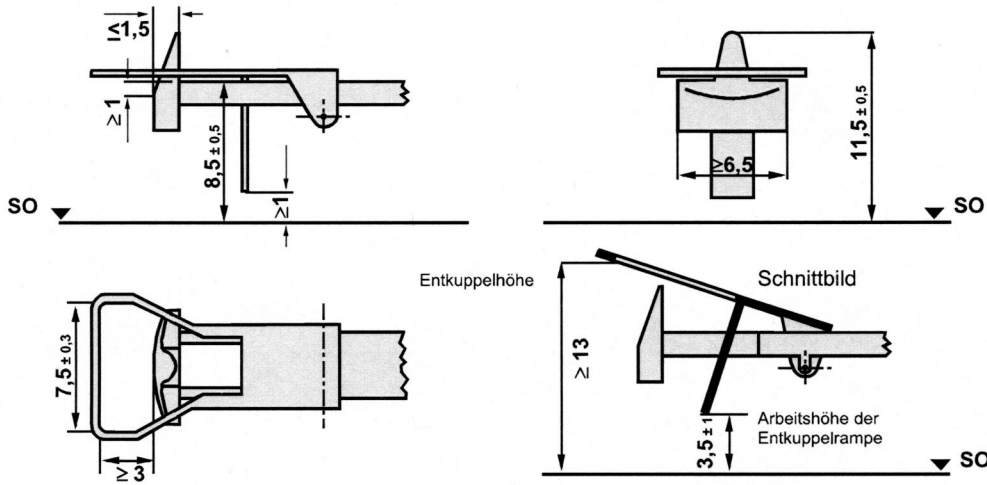

**NEM-360 COUPLER CONVERSION USING KADEE 20 SERIES COUPLERS.**

1. Remove the truck from the underbody.
2. Remove the existing lift coupler trim off upper tab.
3. Mount any 20 Series coupler on the arm attaching it with a screw and shimming coupler as necessary.
4. Use Kadee's® #231 Greas-em graphite lubricant and work coupler back and forth to coat surfaces.
5. Check for correct coupler height, function, and clearance and make any adjustments necessary.

