

BOWSER FORMERLY PENN-LINE

4-4-2 ATLANTIC

No.5® PILOT COUPLER CONVERSION

1. Remove screw holding pilot and loco frame together. File away 1/32" of the bottom front of loco frame about 3/8" back from frame end. Be sure to file flat and level. Drill out hole in frame end with a #43 drill to clear a 2-56 screw. See Fig.1.
2. Cut away a 5/16" wide opening in the coupler pocket and cut to the surface of the top of the coupler pocket. Remove the bottom piece of the coupler pocket, see Fig.1.
3. Assemble No.5® Coupler. Use a plastic compatible cement sparingly along seams only to hold assembly together. Trim side mounting lugs off flush with sides. Cut off front flange of lid flush with top. Secure with a 2-56 screw inserted from below and 2-56 nut above.
4. Check for correct coupler height, function, and clearance and make any adjustments necessary.

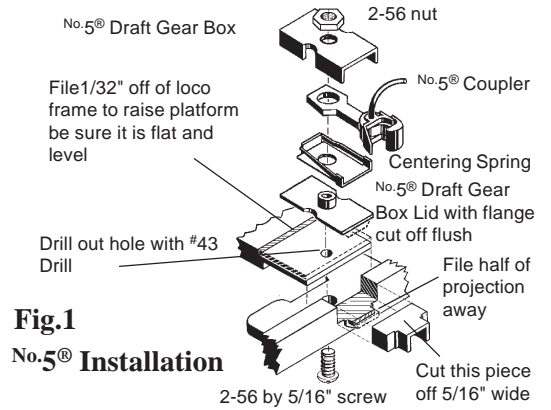

Fig.1
No.5® Installation