

BOWSER FORMERLY PENN-LINE
No.5® COUPLER CONVERSION

LOW SIDE TENDER

1. Cut off coupler pocket bracket flush with bottom of tender frame. See Fig.1. To avoid interference with Draft Gear box, trim protruding ladder ends.
2. Assemble No.5® Coupler. Use a plastic compatible cement sparingly along seams only to hold assembly together. Secure to tender with original self-tapping screw.
3. If Coupler is a bit low, use .010" (Kadee® #209) or .015" (Kadee® #208) washer between tender bolster and trucks to raise coupler.
4. Check for correct coupler height, function, and clearance and make any adjustments necessary.

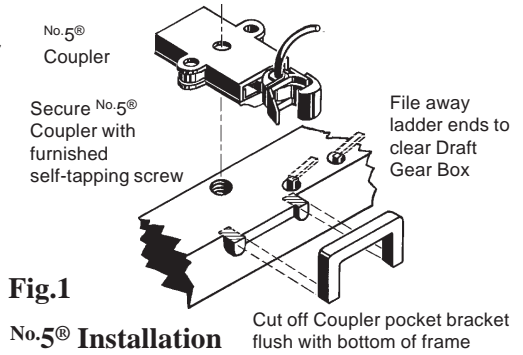

Fig.1

No.5® Installation