

CON-COR

#37 COUPLER CONVERSION

1. Remove the chassis from the body shell.
2. File the coupler pilot opening down to .150" and widen equally to .300" to allow the 30-Series coupler assembly to enter.
3. Drill and tap the coupler mounting hole in the shell for 2-56 threads.
4. Assemble the #37 Coupler with the Coupler on top and the Torsion Spring on the bottom, without the lid. Use a 2-56 screw to secure coupler to shell.
5. Check for correct coupler height, function, and clearance and make any adjustments necessary.

EMD SD-35

Drill and tap existing hole for 2-56 threads

Fig.1
#37 Installation

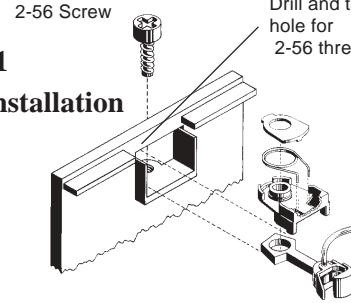

#37 Coupler, assemble as shown, omit lid. Insert through pilot opening and secure with 2-56 screw