

# CROWN

## No.5® COUPLER CONVERSION

1. Remove existing couplers
2. Use screws (metric) that come with model to secure No.5® coupler assembly. Usually there are two screws for each coupler assembly, one for each side mounting lug. If screws are missing or you wish to convert to a single 2-56 screw, drill and tap a 2-56 hole 1/4" from edge of model on centerline. Use a 2-56 screw of appropriate length to secure No.5® Coupler. See Fig.1.
3. Check for correct coupler height, function, and clearance and make any adjustments necessary.

# ALL ROLLING STOCK

Note: Generally the manufacturer has provided metric screws for securing couplers to model. Height adjustments may still be required

Coupler mounting platform may require addition of shims to adjust coupler assembly to the correct height.

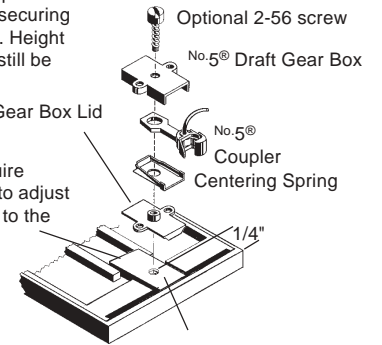

**Fig.1**

### No.5® Installation

For optional 2-56 screw: Drill and tap a 2-56 hole on centerline and 1/4" from edge