

DETAILS WEST

No.5® COUPLER CONVERSION

1. Remove the underframe.
2. Place Centering Spring so it is centered and 1/64" projects over end of floor lid assembly and glue in place with sparingly applied superglue. Place the No.5® Coupler over centerpost in the mounted-on coupler pocket and secure underframe to bottom of floor. Be sure spring is aligned correctly and not in a bind.
3. Place a single .015" thick spacer washer (Kadee® #208) between top of each truck and bottom of underframe bolster to raise coupler height slightly.
4. Check for correct coupler height, function, and clearance and make any adjustments necessary.

ALL ROLLING STOCK

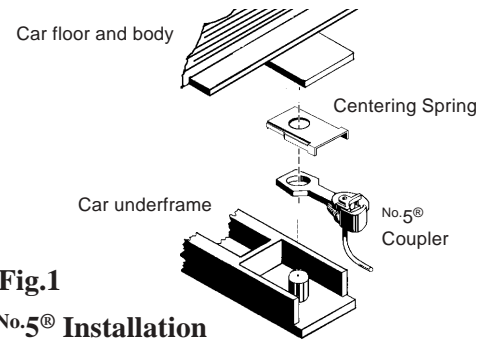

Fig.1

No.5® Installation