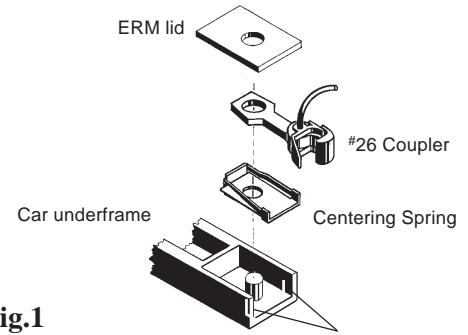

ERM**62'-10" INSULATED BOX (BEER) CAR****#26 COUPLER CONVERSION**

1. Remove coupler pocket lid and existing coupler.
2. Assemble the #26 Coupler with Centering Spring on top and place over centerpost in coupler pocket.
3. Replace manufacturers lid and glue into place with a plastic compatible cement.
4. Check for correct coupler height, function, and clearance and make any adjustments necessary.

**Fig.1****#26 Installation**

Cut off 1/16"
from each
side