

FUNARO AND CAMERLENGO

ALL ROLLING STOCK

No.5® COUPLER CONVERSION

1. Remove existing couplers.
2. Drill and tap a 2-56 coupler mounting hole using draft gear box to determine hole location on car centerline (about 1/4" from edge).
3. Assemble the No.5® Coupler with spring on top. Use a 2-56 plastic screw to secure No.5® Coupler assembly. See Fig.1. Trim protruding screw flush with floor after coupler is secured.
4. Some cars use a washer, provided in kit, between bolster and truck to obtain correct coupler height.
5. Check for correct coupler height, function, and clearance and make any adjustments necessary.

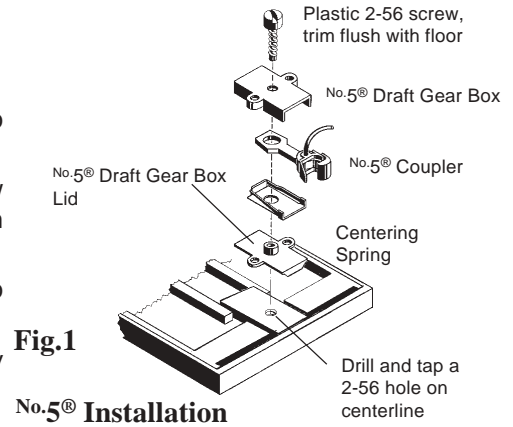

Fig.1

No.5® Installation