

FRONT RANGE TOFC

ARTICULATED UNITS

#27 COUPLER CONVERSION

1. Remove the truck from the underbody.
2. Trim away top inside of coupler pocket until Centering Spring can be inserted. Insert Centering Spring into pocket opening, then insert thick walled bushing from 20-Series sprue and #27 Coupler.
3. Drill center with a #62 drill for a 00-90 screw. Secure assembly with 00-90 screw. Place truck back on the underbody.
4. Check for correct coupler height, function, and clearance and make any adjustments necessary.

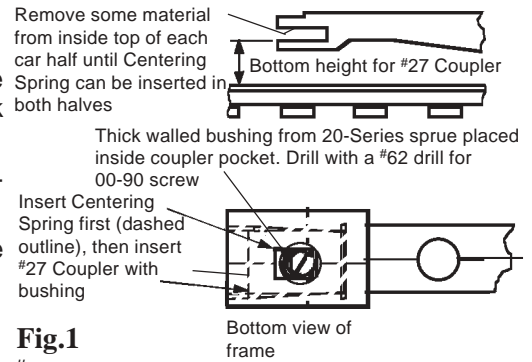

Fig.1
#27 Installation