

HALLMARK (IMPORTED BRASS)

#27 OR #28 COUPLER CONVERSION

1. Remove existing couplers.
2. Use screws (metric) that come with model to secure coupler assembly. Usually there are two screws for each coupler, one for each side mounting lug. If screws are missing or you wish to convert to a single 2-56 screw, drill and tap a 2-56 hole 1/4" from edge of model on centerline. Use a 2-56 screw of appropriate length to secure coupler. See Fig.1.
3. Follow the instructions included with the couplers for assembly and adjustment. If problems are encountered, retrace steps and review generic coupler notes on pages 6 through 9.
4. Check for correct coupler height, function, and clearance and make any adjustments necessary.

ALL ROLLING STOCK

Note: Generally the manufacturer has provided metric screws for securing couplers to model. Height adjustments may still be required

Coupler mounting platform, may require addition of shims to adjust coupler assembly to the correct height

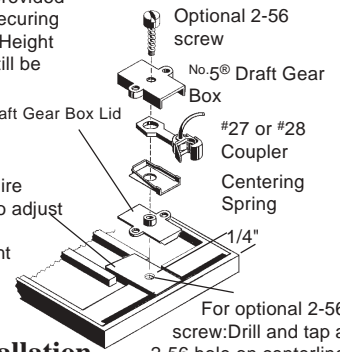

Fig.1
#27 or #28 Installation

For optional 2-56 screw: Drill and tap a 2-56 hole on centerline and 1/4" from edge