

# HOBBYTOWN CHASSIS (ATHEARN)

# EMD GP-9 & GP-30 (TYCO) EMD GP-20

## #8 COUPLER CONVERSION

1. This chassis kit fits a variety of superstructures, therefore there may be differing coupler clearances and you may have to substitute a coupler with a longer shank to clear superstructure.
2. Remove centerpost and side walls of coupler pocket. File pad flat and smooth. Drill and tap existing hole for 2-56 threads.
3. Assemble coupler, install on pad and secure with 2-56 screw.
4. Check for correct coupler height, function, and clearance and make any adjustments necessary.

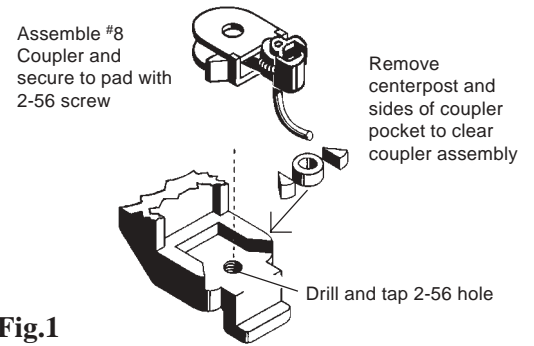

**Fig.1**

## #8 Installation