

LIMA ITALY

ALCO C-420

#38 COUPLER CONVERSION

1. Turn chassis upside down and remove existing couplers.
2. With the body in this position, locate the coupler mounting hole and drill and tap this hole 2-56 by 1/4" deep.
3. Widen the coupler opening in the pilot to 5/16" centered and 1/8" high, measured from top of opening down. Do not remove any part of the top of the coupler opening.
4. Assemble the #38 Coupler with the Lid on top and Torsion Spring on the bottom. Glue coupler assembly together by placing tiny drop of plastic compatible cement along seams only.
5. Insert the #38 Coupler through the coupler opening in the pilot and secure with a 2-56 screw from below.
6. Check for correct coupler height, function, and clearance and make any adjustments necessary.

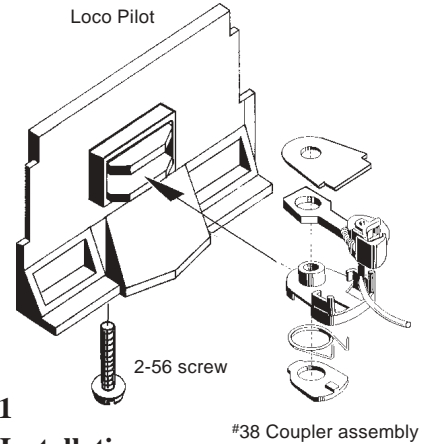

Fig.1
#38 Installation