

MAIN LINE

ALL ROLLING STOCK

No.5® COUPLER CONVERSION

1. Remove existing couplers and discard.
2. Modify coupler stirrup on car end by cutting off flush with bottom of end sill. See Fig.1.
3. Assemble No.5® Coupler with spring on top. Glue lid to box with a small amount of plastic compatible cement placed along seams only.
4. Place No.5® coupler assembly on car centerline and flush with end of car. Use small wood screw to secure to car body. See Fig. 2.
5. Check for correct coupler height, function, and clearance and make any adjustments necessary.

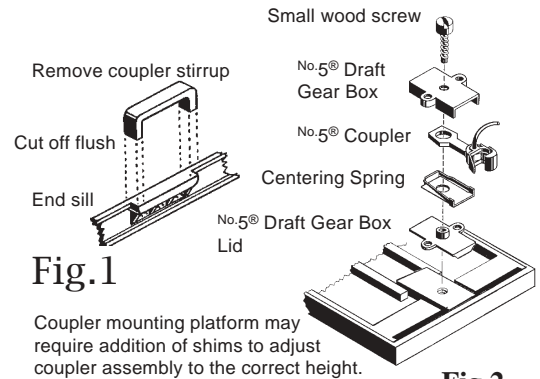

Fig.1

Fig.2

No.5® Installation