

MDC - ROUNDHOUSE

#4 COUPLER CONVERSION

OLDER ALL DIE-CAST TENDER MODELS

1. Remove existing coupler screws, coupler pocket lid and coupler. Clean off all flash.
2. Assemble the #4 Coupler by first sliding the Spring Dowel into the Centering Spring.
3. Place the #4 Coupler over the solid cast-on centerpost of the coupler pocket, see Fig.1. Carefully insert the coupler Centering Spring and Dowel into the slotted opening in the coupler shank behind the centerpost of the coupler pocket.
4. Secure Roundhouse lid with the two screws.

#28 COUPLER CONVERSION

NEWER DIE-CAST AND PLASTIC TENDER MODELS

5. Remove existing coupler screw, coupler pocket lid and coupler. Clean off all flash.
6. Test Centering Spring for fit. If necessary, widen coupler pocket to fit Centering Spring by filing equal amounts from both sides.
7. Assemble the #28 Coupler with Centering Spring on top. Place coupler assembly into Roundhouse coupler pocket, place Roundhouse lid on top and secure with screw, see Fig. 2.

#28 COUPLER CONVERSION FOR SWITCHER PILOTS

#26 COUPLER CONVERSION FOR COW CATCHER PILOTS

8. Remove existing coupler screws, coupler pocket lid and coupler. Clean off all flash.
9. Test Centering Spring for fit; If necessary, widen coupler pocket to fit Centering Spring by filing equal amounts from both sides.
10. For side by side screw mounting with no centerpost: Modify the No.5® Draft Gear Box Lid (included with 20-Series Couplers) by cutting off top front flange. Assemble the #28 or #26 Coupler with Centering Spring on top over hub of No.5® lid. Place the coupler assembly with lid into Roundhouse coupler pocket and secure with screws, see Fig.3.

11. For single screw with centerpost mounting: Use the Roundhouse coupler pocket lid. Assemble the #28 or #26 Coupler with Centering Spring on top over centerpost of the coupler pocket. Place the lid on the Roundhouse coupler pocket and secure with screw, see Fig.3.

12. Check for correct coupler height, function, and clearance and make any adjustments necessary.

FOR STEAM LOCOS

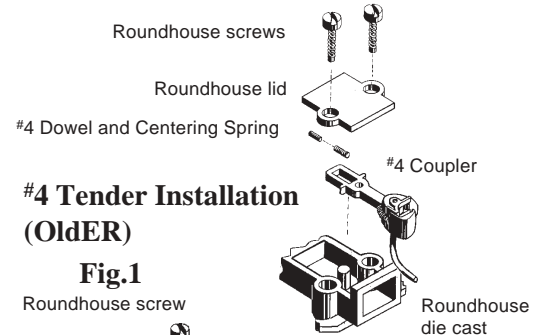
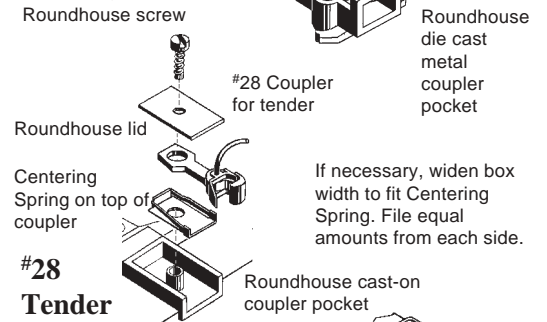

Fig.1



#28

Tender

Installation

(Newer)

Fig.2

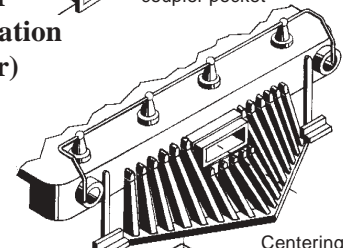

Fig.3

#28 or #26 Pilot Installation