

MDC - ROUNDHOUSE

BOX CAB DIESEL

No.5® COUPLER CONVERSION

1. Couplers drop into the plastic coupler box assembly without any cosmetic changes other than cleaning out any flash.
2. Place the coupler into the box with the Centering Spring on top of the coupler and the lid on the bottom.
3. Secure the coupler assembly to the box with the screw furnished with the kit.
4. Check for correct coupler height, function, and clearance and make any adjustments necessary.

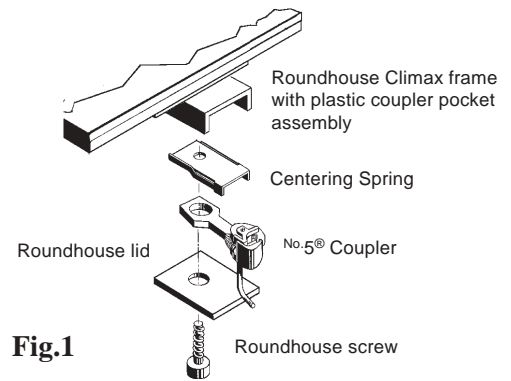

Fig.1

No.5® Installation