

MDC - ROUNDHOUSE**HOPPER SAND & GRAVEL, ALL METAL****#4 COUPLER CONVERSION**

1. Remove existing couplers.
2. Assemble the #4 Coupler by first sliding the Spring Dowel into the Centering Spring.
3. Place the #4 Coupler over the centerpost of the coupler pocket and carefully insert the coupler Centering Spring and Dowel into the slotted opening in the coupler shank behind the centerpost of the coupler pocket.
4. Use a Kadee® #204 Adaptor Plate which will act as a spring stop and place it on top of the coupler.
5. Assemble the lid over the adaptor plate and secure it with the two screws.
6. Dust the coupler with Kadee® #231 Grease-Em and lightly work the coupler back and forth to spread the graphite and coat the surfaces.
7. Check for correct coupler height, function, and clearance and make any adjustments necessary.

#4 Couplers have been discontinued.

Kadee® has some #4 coupler only available by special request. You will need to email Kadee to inquire about #4 coupler onlys.

#148 with a #213 sleeve (to change the pivot hole diameter) should work in place of the #4 coupler. Some filing and trimming of the cast on gearbox may be required for clearance.

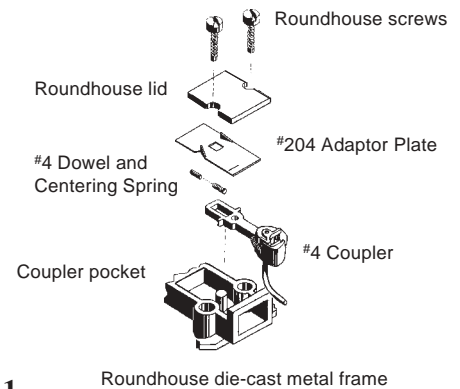
**Fig.1****#4 Installation**