

MDC - ROUNDHOUSE

OLD-TIME PASSENGER CARS 50'

No.5® OR #58 BODY MOUNT COUPLER CONVERSION

1. Remove existing screw, lid and coupler on both ends. Save screws and lids.
2. Assemble the No.5® Coupler with Centering Spring on top and place in coupler pocket over centerpost.
3. Place lid over coupler assembly and the cast-on coupler pocket and secure with the original screw.
4. Check for correct coupler height, function, and clearance and make any adjustments necessary.

Note: Some minor variations occur depending on type of car or production run. This may require the addition of one or more shim washers between truck and bolster for correct coupler height. Metal frames and/or metal coupler pockets should have plastic couplers. See individual cars listed below for additional specific instructions.

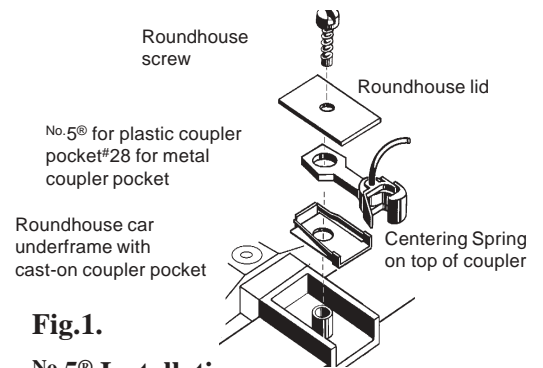
**Fig.1.****No.5® Installation**