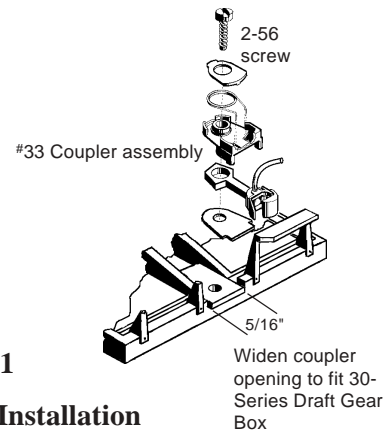

**REVELL****0-6-0T SWITCHER****#33 COUPLER CONVERSION**

1. Remove screws and couplers.
2. Widen coupler pockets by removing material equally from both sides until they allow a 30-Series Draft Gear Box to slide in.
3. Drill and tap on loco centerline new 2-56 coupler mounting holes  $5/32$ " from front of pilot coupler pocket and  $1/4$ " from the end of the rear coupler pocket.
4. Assemble the #33 Coupler with the coupler on top and the Torsion Spring on the bottom. Glue assembly together by placing tiny amount of plastic compatible cement along seams only.
5. Install the #33 Coupler from below and secure with a 2-56 by  $1/4$ " screw.
6. Check for correct coupler height, function, and clearance and make any adjustments necessary.

**Fig.1****#33 Installation**