

# REVELL

# ALL FREIGHT CARS

## No.5® BODY MOUNTED COUPLER CONVERSION

1. Remove trucks and cut off coupler brackets with couplers just past truck bolsters.
2. Drill and tap a 2-56 coupler mounting hole on car centerline 1/4" from end.
3. Assemble the No.5® Coupler with the Centering Spring on top. Glue assembly together by placing tiny amount of plastic compatible cement along seams only.
4. Place two .015" shims (Kadee® #211) over coupler mounting hole between car body and coupler. Install the No.5® Coupler over shims, align holes and secure with a 2-56 by 1/4" screw. Trim off excess screw flush with inside car floor.
5. Check for correct coupler height, function, and clearance and make any adjustments necessary.

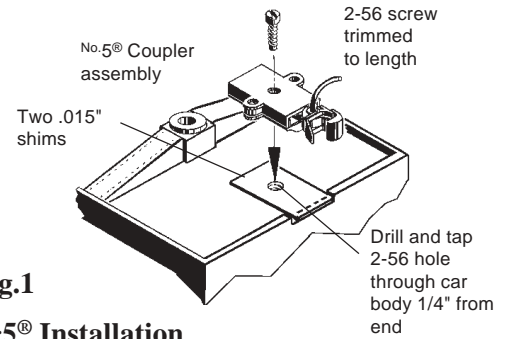

**Fig.1**  
**No.5® Installation**