

TYCO

0-8-0 CHATTANOOGA

No.5® PILOT COUPLER CONVERSION

1. Remove existing coupler.
2. Modify the pilot coupler opening by removing sides and bottom completely. Make opening 5/16" wide. Remove top of pocket until it is flush and level with bottom side of pilot deck. See Fig.1.
3. Assemble the No.5® Coupler with the Centering spring on top. Glue box and lid together with a small amount of plastic compatible cement. After glue has dried, modify the No.5® box and lid by cutting off the side mounting lugs. See Fig.1.
4. Install No.5® coupler assembly in pilot from the front, center and secure with glue. If you wish, you may secure coupler with a 2-56 screw. To do this, drill and tap a 2-56 hole on loco centerline 1/4" from the front of the coupler pocket. Then use a 2-56 screw of appropriate length to secure coupler.

#27 TENDER TRUCK (TALGO) COUPLER CONVERSION

5. Assemble the #27 Coupler into the truck mounted coupler box according to the 20-Series instructions. See Fig.2.
6. Check for correct coupler height, function, and clearance and make any adjustments necessary.

NOTE: For body mounted coupler installation use a No.5® Coupler and shim to correct height.

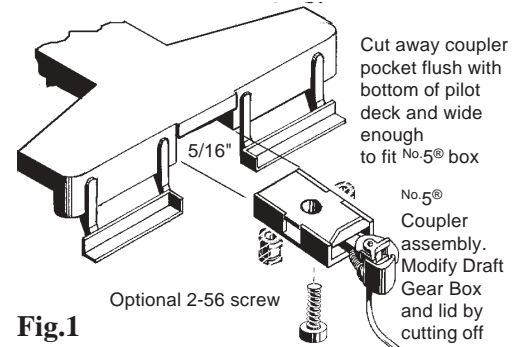

Fig.1

No.5® Pilot Installation

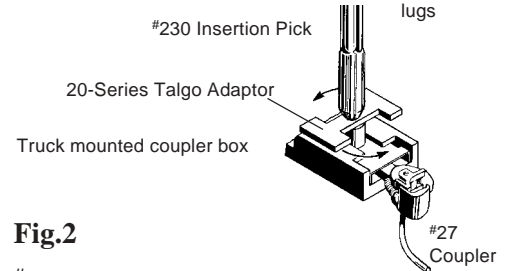

Fig.2

#27 Tender Installation