

TYCO

2-8-2 MIKADO

#38 COUPLER CONVERSION

1. Remove existing couplers, save screws.
2. For pilot: Check pilot coupler opening with 30-Series Draft Gear Box. If not wide enough, remove material equally from both sides until opening is 5/16" wide.
3. With loco on its back, slide .025" shim into coupler opening from the front and align holes. Assemble the #38 Coupler with Torsion Spring on bottom and Coupler on top. Install the #38 Coupler by sliding assembly into coupler opening from the front of the pilot with shim on top. Align holes and secure with Tyco screw. See Fig.1.
4. For tender: Assemble #38 Coupler with Torsion Spring on top and coupler on bottom. Install 30-Series Coupler onto tender from below and secure with Tyco screw.
5. Check for correct coupler height, function, and clearance and make any adjustments necessary.

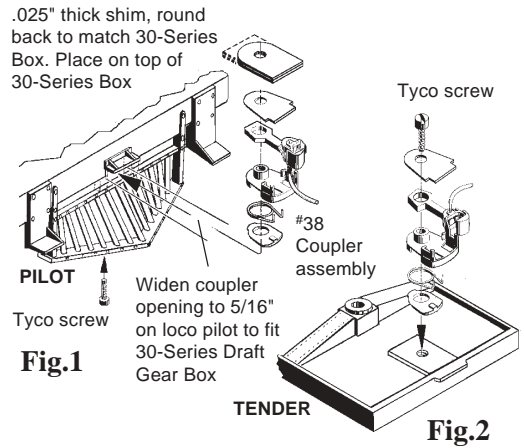

#38 Installation